

INSTRUCTION MANUAL

Fair American

1780 18th Century War Brig

TECHNICAL CHARACTERISTICS

Scale: 1/4" = 1 Ft.

Length: 26-1/2"

Height: 22"

Intermediate Level Kit

By Erik A. R. Ronnberg, Jr.

With revisions by
Ben Lankford

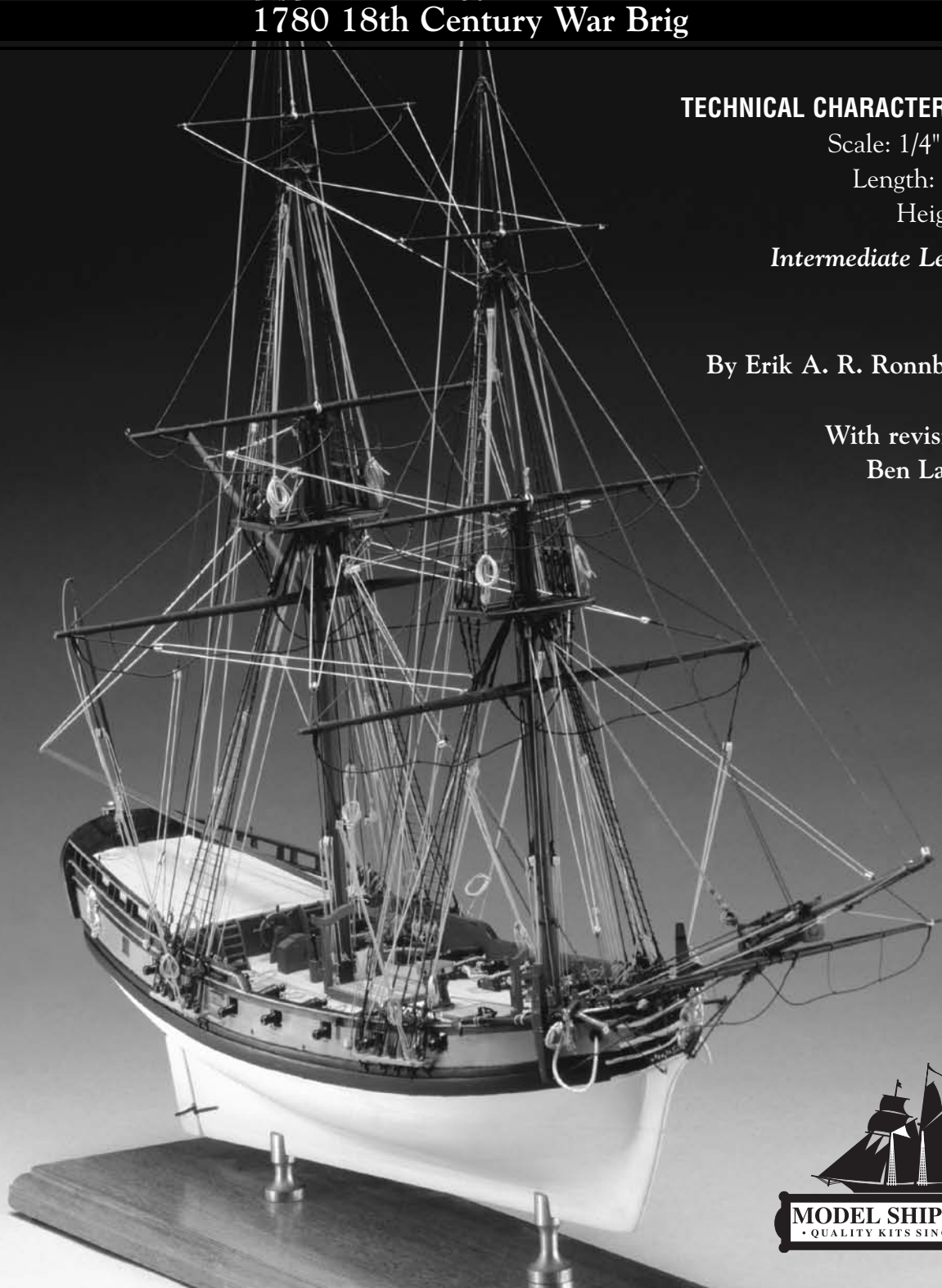

MODEL SHIPWAYS
• QUALITY KITS SINCE 1946 •

MODEL SHIPWAYS

KIT NO. MS2015



TABLE OF CONTENTS

History	3
Acknowledgements	3
Model Construction	4
Preliminaries	4
Reading Plans and Following Instructions	4
Tools	5
Concerning Glue	6
Building the Plank-on-Bulkhead Hull	6
Painting the Hull	18
Mounting the Hull	19
Making Masts and Spars	21
Rigging	24
Bibliography	37
Key to Rigging Plan	38
Rigging Tables for Fair American	39
Parts List	44

Published by
Model Shipways, Inc.

© Copyright 2005

1st Printing 1978

Second Printing 1981

Third Printing 1988

Fourth Printing 2005

INSTRUCTIONS FOR KIT OF THE REVOLUTIONARY WAR BRIG FAIR AMERICAN, c. 1780

by ERIK A. R. RONNBERG, JR.

HISTORY.—Your kit of the Revolutionary War brig FAIR AMERICAN is based on Model No. 60 in the Henry Huddleston Rogers ship model collection at the U.S. Naval Academy Museum, Annapolis, Maryland. The model's origin is uncertain: one claim asserts that the model was made by the British Admiralty after the vessel's capture to study her fine hull form and enormous rig; another faction has argued that the model was made in America and subsequently used as a guide for a painting of a naval engagement involving the original brig. All that is certain is that the model was in English hands prior to its acquisition by Colonel Rogers and one can only wonder how the model got there if it had been made in America during the turbulent post-Revolutionary period, and by whom, assuming time, money, and talent were available for such an involved undertaking.

Due to the number of vessels named FAIR AMERICAN which participated in the Revolution and the amount of conflicting data pertaining to these names, it is virtually impossible at this time to identify the FAIR AMERICAN which the Rogers model represents. A brig of that name which closely resembles the model participated in the GENERAL MONK—HYDER ALLY engagement of April, 1782. A painting by Verney of this action is in the Naval Academy Museum and the resemblance between the brig depicted and the Rogers model is close, but not conclusively so, and any further association between the model and this painting can only be conjecture, pending further evidence. It should be added that at the time of that engagement, the brig was under English colors, having been captured from the revolutionaries a year or two previously. She was retaken by the Americans in the course of pursuing the HYDER ALLY'S convoy up the Delaware when she ran aground.

The Rogers model, whatever FAIR AMERICAN she represents, is an interesting example of a rigged block model from her period. If built for the Admiralty, it may have been a "rush job" intended to answer pressing questions about hull form and rigging without regard for the time-consuming frills commonly associated with "Admiralty models". The finish and carvings are a bit crude, and the ravages of time and wood shrinkage have not enhanced these features. Workmanship of the rigging and rigging fittings is more impressive and one wonders if rigging and sails were not the more important objects for Admiralty study, assuming this was the model's purpose.

The model's rigging betrays some apparent anachronisms, the dolphin striker and main boom topping lift being the most obvious. Have there been efforts to "improve" the model's rigging during subsequent repairs or, if all rigging is truly contemporary, do we need to revise some of our notions about 18th century rigging practice? Certainly the Verney painting, done in 1802, cannot be wholly trusted and the fact that many of the Rogers models have been re-rigged, or newly rigged while in Rogers' possession, might mean that all details of this model's rigging may not be trustworthy. A book review of the Rogers Collection catalog by R. C. Anderson in the MARINER'S MIRROR, vol. 41, 1955, p. 85 gives a fuller discussion of this controversial situation.

The rigging of FAIR AMERICAN, as drawn in these kit plans, has been revised to agree with rigging practice described in Steel, **Elements of Mastmaking, Sailmaking, and Rigging** (1794). Those wishing to rig their models with sails are advised to consult the sailmaking directions in Steel, using photographs of the Rogers model as a guide. For those who insist on replicating the rigging of the Rogers model, including doubtful elements, photographs of the model in the Rogers Collection catalog will readily show the details in question. A bibliography of source material used in the Model Shipways plans is included in the back of this booklet.

ACKNOWLEDGEMENTS

The kit described herein is essentially a "model of a model" with only minor changes as mentioned previously. The Model Shipways plans as drawn by John R. Stevens have been left in their original format, the principal alterations being more labels, some additional views in the spar plan, revisions and additions to the rigging plan, and a new belaying pin plan. In the main, Stevens' conception of this kit as a modified project for kit modelers remains unchanged.

Our thanks to the Curator of the U.S. Naval Academy Museum for permission to take the lines off the model.

I am grateful to William A. Baker, Curator, Hart Nautical Museum, Massachusetts Institute of Technology, for taking time to study the revised plans, checking the labels, and offering suggestions on terminology and rigging alterations.

In the course of altering the drawings, a model of the FAIR AMERICAN model built to test ideas and iron out the usual headaches over finding all the proper rigging leads. The model, illustrated herein, was made jointly by me

and my father, Erik A. R. Ronnberg, Sr., to whom I am grateful for making numerous revisions and waiting patiently for me to do my bits of the model's construction and finishing.

Finally, thanks to Model Shipways Co. for ransacking its files for past gleanings and feedback on this kit, and for their patience with any number of delays, corrections, afterthoughts, daydreams, and other dalliances with which I have plagued them.

MODEL CONSTRUCTION

PRELIMINARIES

This particular kit and instruction book reflects a modified Model Shipways Fair American model kit from a solid hull model to a plank-on-bulkhead (P-O-B) hull construction. The instructions and drawings for the P-O-B hull construction were prepared for Model Shipways by Ben Lankford. Sheet 1 through 4 are unmodified from the original kit. Sheet 5 and 6 have been added to the kit for the P-O-B configuration.

You will notice that Figure 1 through 15 in this revised instruction book are a bit unusual in numbering, some being A, B, C, etc. This was done to fit the new sketches in the text and retain the Figure numbers in the later part of the book. All text and Figures which described the original solid hull construction have been removed and replaced by new text and sketches applicable to a P-O-B hull. Model Shipways hopes you enjoy this "change of pace" and find a most challenging and rewarding experience ahead.

This kit is to the approximate scale $\frac{1}{4}'' = 1'$, but more nearly approaches the metric scale 1:50; however, the use of drafting scales to either calibration will give sufficiently accurate results.

While a rig of this sort is not recommended for the novice building his first model, advanced beginners will find working to this large scale is easier than building a similar model to a smaller scale like $\frac{1}{8}'' = 1'$. Many of the features of this hull and rig will be similar to those of a larger man-of-war, so the prudent modelmaker who is working his way up to a CONSTITUTION or ESSEX will find this kit a constructive "primer" to the intricacies of larger naval vessels.

READING PLANS AND FOLLOWING INSTRUCTIONS.

The greatest bugbear and deterrent to the average shipmodeler is that of understanding scale drawings and following a logical sequence of construction. The thing to bear in mind with plans is that they are drawn to scale, the size of the model in the drawing being exactly the same size as the model you are to build. If a hatch in the drawings measures $1\frac{3}{4}''$ long by $1\frac{1}{4}''$ wide by $\frac{1}{8}''$ high, then those are the dimensions of the corresponding hatch on your model. Right away this should tell you that measuring all parts, or finding their dimensions, is a critical part of modelmaking and you should be properly equipped for this essential work. If you have an old set of engineer's drafting tools in your possession, you have made an important first step. If not, perhaps an engineer friend can loan you an old set or purchase a used set for you. College bookstores and pawn shops are excellent hunting grounds for used drafting instruments. If you must resort to purchasing individual instruments, then you will find the following useful:

1. 6" dividers with needle points.
2. 5" spring bow dividers (These open and close by turning a thumb-wheel.) with needle points.
3. Spring bow dividers with one pencil point.

Useful but not essential is an architect's scale rule, but try to get one with as few different scales as possible to avoid confusion. A flat scale ruled only to $\frac{1}{4}'' = 1'$ or to metric 1:50 would be ideal. A machinist's steel rule (6") is indispensable and inexpensive; get one that's ruled in $\frac{1}{32}''$ and $\frac{1}{64}''$ divisions on one side and $\frac{1}{10}''$ (0.1") and $\frac{1}{100}''$ (0.01") divisions on the other.

A cheap, accurate, but not always convenient way of transferring dimensions from plans to model is with **tick strips**, a narrow piece of paper being placed on the plan beside the object to be measured, the object's dimensions being transferred by making tick marks with a sharp pencil on the edge of the strip. The dimensions marked on the strip can now be transferred to the construction material from which the part in question is to be made. This method has the virtue of recording dimensions or distances for re-use or later consultation, **provided** notes are made on each strip as to what each mark records. This requires organization of thought and work habits, and the sooner you apply yourself to these ends, the better.

So far as following instructions is concerned, the sequence offered herein is one that the author has found practical in the course of building nearly 100 models. If you don't like it, you are free to choose your own order of construction and you may have a better model to show for it; however, beginners might do well to follow this text

closely to avoid pitfalls and awkward situations. If you think you can make fittings which seem better than the castings provided, by all means do so; the more you add of your own handiwork, the more confidence and pride you will have in your model and the closer you will come to scratch-building the ultimate goal of all kit modelers.

You should now familiarize yourself with all parts of the kit. Take out all wood parts, measure them, match them to the list of wooden parts, and mark each piece to identify it. All parts in the fittings package should also be taken out, matched to their counterparts in the plans, labeled, and carefully boxed or sorted in small envelopes for ready access in the future.

Before commencing work, you may wish to read these instructions from cover to cover to get a better idea of the construction sequence and some of the problems to be encountered. Many of the smaller subsequent operations can be tackled individually while you are waiting for glue or paint to dry. When you've done all you can for one item that needs curing time, there's always something else that needs tinkering. Methodical fiddling with small parts can boost your efficiency considerably and you'll be surprised at your progress.

TOOLS

Measuring tools have already been discussed in the previous section, and they will be necessary for all modelmaking operations. Breaking down tool requirements by major phases of construction, we have:

A. Plank-on-bulkhead hull construction:

1. Knives—X-acto with No. 11 blades.
2. 18 inch aluminum or steel straight edge.
3. Sandpaper—Nos. 100, 150, 240; homemade sanding block.
4. Small chisel—blade 1/2 inch wide or less.
5. Needle files.
6. Lill pins.
7. Small machinist square.
8. Weights (lead or other medium weight blocks).
9. Small block plane.
10. Clamps for installing planking.

B. Rails, deck, hull fittings:

1. Coping saw or jeweler's saw frame and fine blades.
2. Razor saw (X-acto or Zona)
3. Pinvise and drills ($\frac{1}{8}$ ", $\frac{3}{32}$ ", $\frac{1}{16}$ ", #60, #65, #70, #75).
4. Pliers—round-nose (for forming rings and eyes in wire) and chain-nose with serrated jaws (for general work).
5. Hammer—Jeweler's type, 1 oz. head or smaller.
6. Wire cutters—square nose or diagonal.
7. Needle files—round, square, half-round, equalling, Barrette, three-square (triangular).

C. Priming and painting:

1. Stains for natural wood finishes.
2. Primer for surfaces to be painted.
3. Paint.
4. Thinner and brush cleaner.
5. Brushes—fine (#0), medium (#4), wide (#12), round sable or sabeline.
6. Sandpaper—wet-or-dry, 220-, 320-, and 400-grit.

D. Masts and spars, add:

1. 10" flat file, coarse.

E. Rigging:

1. Tweezers—stainless steel preferable with blunt ($\frac{1}{32}$ " wide) serrated tips.
2. Scissors—fine surgical or manicure type, short curved blades preferred.
3. Bees wax and liquid wax shoe polish (optional) for tinting cordage.
4. Strapping wire (#32 soft iron) for blocks.

The above list is "basic" for a project of this complexity and you will probably want to add to the list based on past modelmaking experience and your own creative intentions. If you are a relative newcomer to this art, settle for middle-priced tools and work with them until you know their capabilities (and yours); then, if you want to invest in costly hardware, you will know what you're looking for.

CONCERNING GLUE

The types of glue to use or avoid is a confusing topic for the beginner and often an emotional one for the experienced. Synthetic resin, "white glue", such as Elmer's Glue-All or Titebond is probably the best choice for bonding wood to wood or to paper and is very easy to apply. Acetate glues, for model aeroplane construction, are not recommended; they work well on porous balsa wood, but cannot penetrate close-grained pine or basswood for an effective bond. Catalyst-resin glues, such as epoxy, are very strong but very hard and will ruin a cutting-edge or file when these tools are used to remove excess or accidental smears. These glues must also be carefully mixed, a tricky job in the small quantities needed. However you choose, use any glue sparingly and **neatly**; small toothpick applicators have prevented many a heartache. For strong, snug fits, pin the pieces together or clamp them with clothespins, rubber bands, paper clips, etc. Miniature clamps for model makers are commercially available.

For gluing metal to wood, or to other metal, the more modern adhesives are decidedly the best. Acetate glues (Duco or Ambroid), contact cements (Pliobond or Weldwood), and catalyst-resin glues (Devcon or Marine-Tex) all work well, the last mentioned especially so. Ideally, parts to be joined should be socket-joined or dowelled with wire for greatest strength. It is also advisable to scuff gluing surfaces with a file or sandpaper to give "bite" for the glue.

BUILDING THE PLANK-ON-BULKHEAD HULL

Note: Due to the fact that saw mill tolerances are not nearly as precise as a computer controlled laser cutting machine, you may find it necessary to thickness sand the center keel sections and bulkheads to allow the pieces to fit together.

Centerkeel and Bulkhead Assembly.—The first, and perhaps most important, step in constructing the hull is assembly of the centerkeel. This keel, or more appropriately called a centerline bulkhead, must be straight, and level on the lower edge. Place the two parts, piece A and B, over a sheet of wax paper or plastic wrap to prevent glue stick. Glue the two sections together with white glue or titebond and butt the lower edge against a steel or aluminum straight edge. Place a weight on each section of the assembly. Your working table or building board itself must be as flat and even as possible. You could also use a piece of plate glass as a building board to assure a flat surface. Allow the glue to dry thoroughly, at least 24 hours. See Fig. 1A.

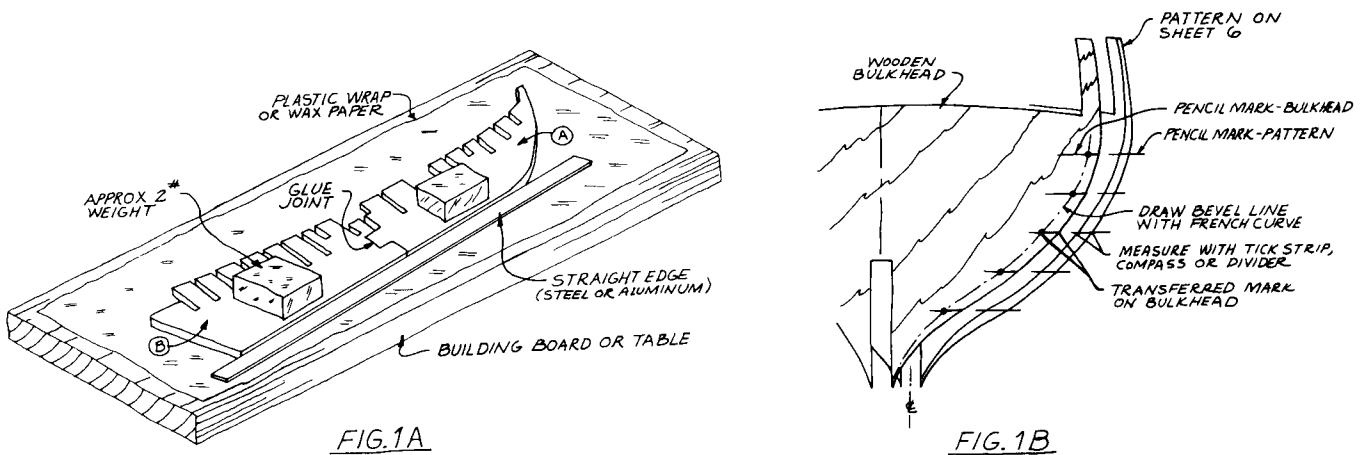

While awaiting the centerkeel to dry proceed to cut the bevels on each bulkhead; the outer edge, the inboard side of the bulwark stanchions which protrude above the bulkhead from the deck level, and the top edge (main deck level). First, match the overall shape of each bulkhead supplied in the kit against its pattern on sheet 6 of the drawings and label each one. If necessary trim the bulkhead to suit the pattern. There could be a mismatch as a result of the manufacturing process or a wrong bulkhead included in the kit (heaven forbid). Draw a centerline on each bulkhead. Next, using the patterns transfer the bevel line to the bulkheads. The most accurate way to do this is to draw the bevel line on the bulkhead using a pencil and French curve. You must first measure and plot some points on the bulkhead from the patterns. Fig. 1B shows how. You need some lines like the waterlines drawn on the bulkhead and pattern to give you some locations to measure. There are other methods as well. One such is to use carbon paper to trace the bevel line on the bulkhead from the pattern, lay it over its hull part and use a pin to prick a line of tiny holes along the line of the bevel. Remove the paper pattern and connect the pin pricks with a fair pencil line on the wood. Careful! Make sure you draw the line and cut the bevels on the correct side. File and sand the

edges smooth. See Fig. 2A. Also, be careful handling Bulkheads 5, 6, 8, and 9. Only a little wood is left between the hatch cuts and centerkeel slots. If you worry about breakage glue a strip of wood in this area to strengthen it.

When the centerkeel is dry, draw the bearding line in pencil on the centerkeel using the pattern cut from the plans sheet, and the pin prick method. Or you may tick off the measurements from the centerkeel and draw the line on *both* sides. To help locate points from the plan draw a line at each bulkhead slot, extended down to the bearding line. You will also need these guide lines later to correctly align the bulkheads on the centerkeel.

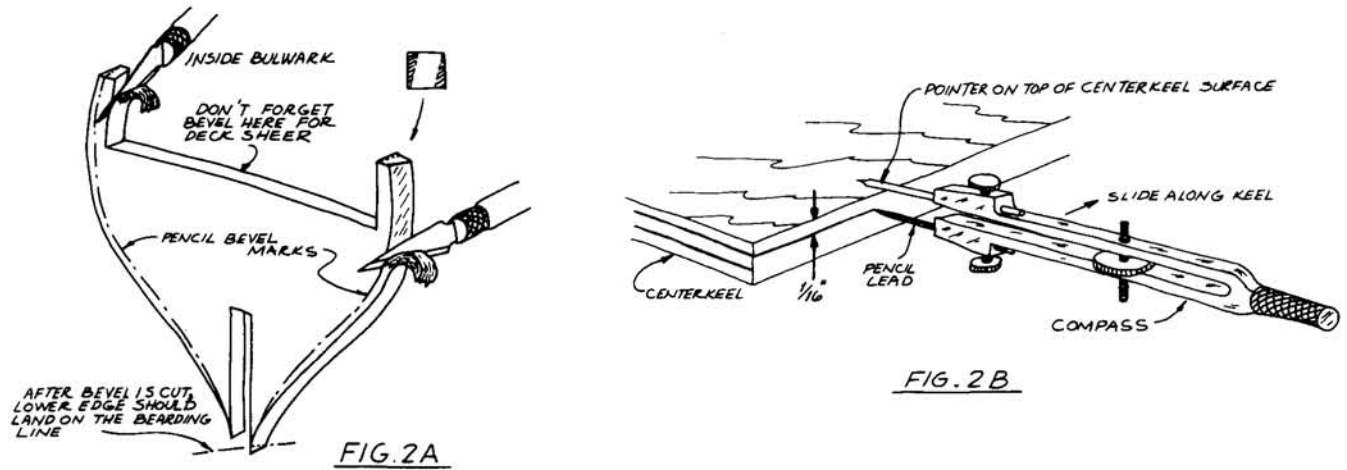

The next job is to cut the rabbet, the slope from the bearding line to the rabbet line. At the rabbet line, which at this point corresponds to the outer (front, rear and bottom) edges of the centerkeel, the depth is 1/16 inch on both sides so that the 1/16 inch hull planking will fit flush. Mark the depth on the centerkeel using the method shown in Fig. 2B. Notice from the sketches on sheet 6 that a simplified model rabbet is being cut and not full scale practice. Take your time cutting the rabbet. Since the keel, stem and sternpost have not yet been installed on the centerkeel piece the lower edges are a little delicate, especially at the stern. You can use an X-acto knife and fine files for much of the rabbet. For the long slope at the stern you will need a flat chisel. See Fig. 3.

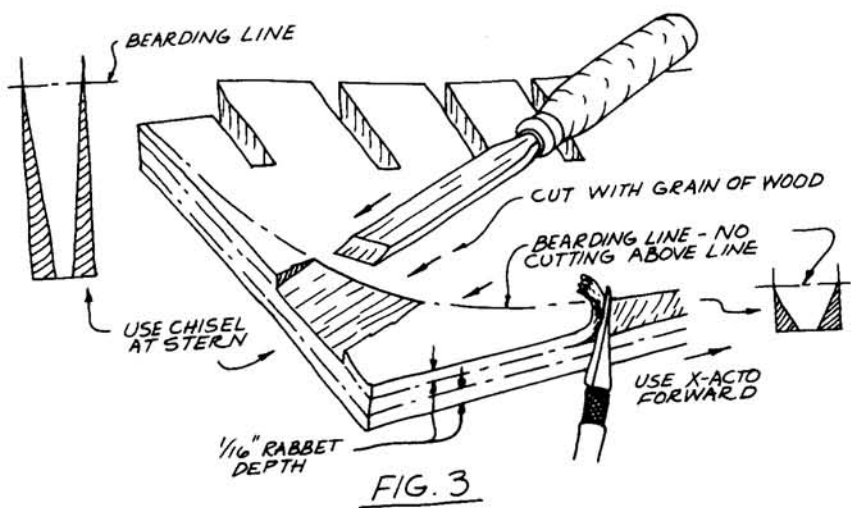

When you are satisfied that the rabbet is reasonably accurate, glue the keel, stem, and sternpost onto the centerkeel piece. Again, lay the centerkeel piece flat on your building board over some wax paper or plastic wrap, then glue the three pieces. Shape the three pieces first from the plans, and fit them accurately to the edges of the centerkeel. As noted on the plans you can add a wooden dowel or pin through the keel into the stem and sternpost for added strength. After the glue has dried, recheck the rabbet, clean out any glue squeeze-out, then check-fit a small piece of 1/16 inch plank in the rabbet at the keel, stem, and sternpost. The outer edge of the plank should be flush with the sides of the keel, stem, and sternpost. If not, chisel here and there until it is correct. See Fig. 4. At this time you can taper the stem according to the dimensions shown on the plans. The next step is to check-fit all the bulkheads. Insert each bulkhead in the correct numbered bulkhead slot. If the fit is too tight, sand to loosen. It

should fit snugly. The top of each bulkhead at centerline (the main deck), except for No. 16, should be flush with the top of the centerkeel piece. Also, the bottom edge should land precisely on the bearding line you drew in pencil. Trim as necessary for a good fit. Next, glue the bulkheads in place one at a time. Line up each bulkhead with the pencil marks you drew at each bulkhead slot. Use a small machinist square or a small triangle cut from wood with a 90 degree angle to set the bulkheads perpendicular to the centerkeel. Tack or tape a small strip of wood on top of each bulkhead to hold them at the correct position until the glue dries. See Fig. 5.

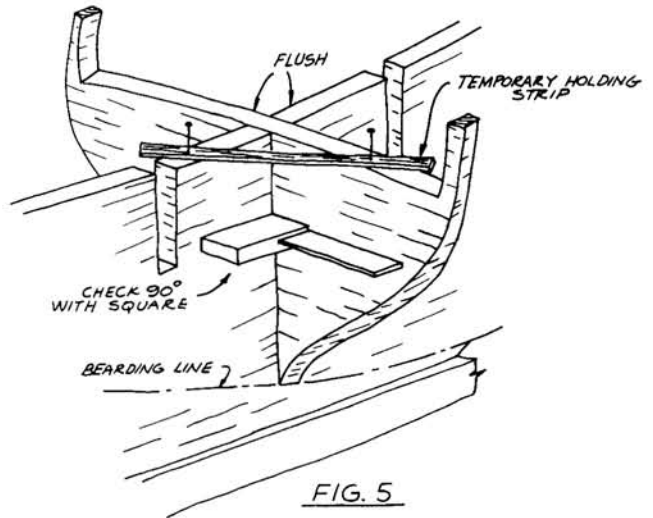
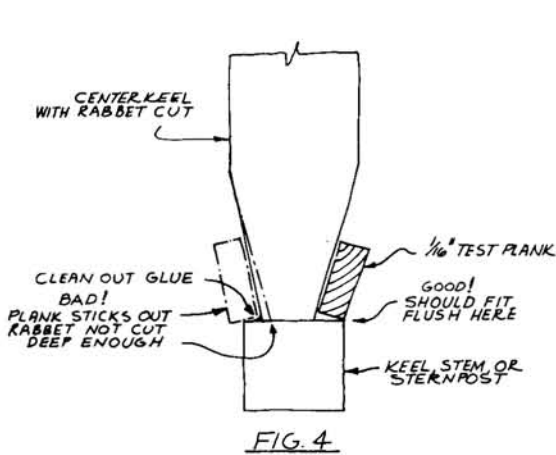

After all the glue has dried check that the bottom of the bulkheads fair in at the bearding line. Sand these areas so that a piece of plank will slide smoothly from the bulkhead onto the keel. See Fig. 6. Tack a temporary strip of wood or install the permanent waterway on the main deck against the extended bulwark stanchions. Measure the spacing between the bulkheads before securing. Check both sides. The waterway, or temporary strip, will give rigidity to the whole assembly and maintain the bulkhead spacing. You should also add a temporary strip at the top of the bulwark stanchions to hold them rigid until the cap rail is added. The assembly will look like Fig. 7. At this point you can make a cradle for holding the model to make the remaining work easier.

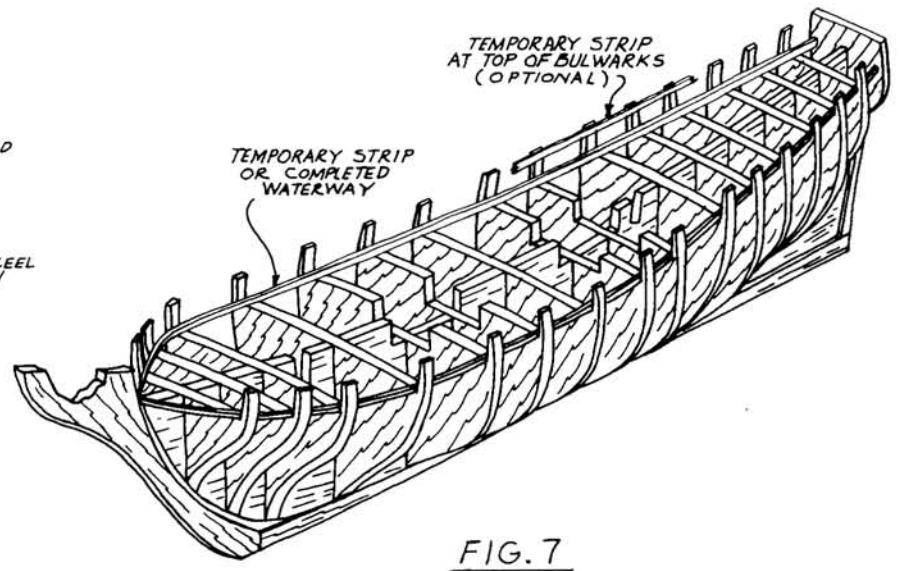
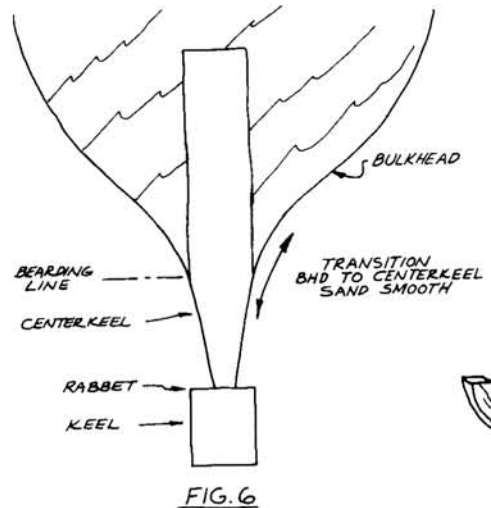

If the bulkheads were properly tapered and placed correctly on the centerkeel you should have a reasonably fair hull. However, wood warps and human error creeps in. Take a length of 1/16 inch thick plank and bend it over the bulkheads. In all areas the plank should lie flat against the bulkhead edges. If necessary sand the areas that seem to have humps and bumps until all is fair. Once you start the planking chore you do not want to be fussing with the bulkheads. See Fig. 8. Sand and look and recheck. Put it down, have a coke, then take another look. Also, check again that the planks will flow into the rabbet at various points. The centerkeel and bulkhead assembly is now complete and you are ready for additional framing and planking.

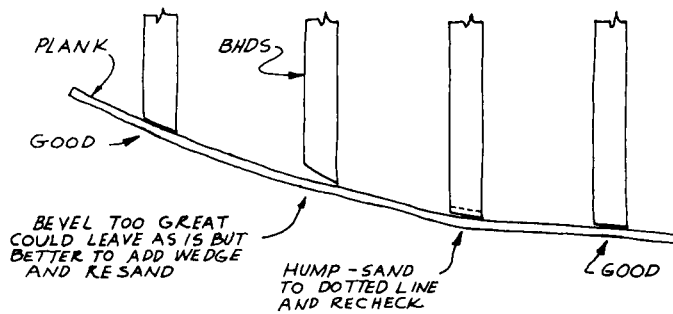

FIG. 8

A Word of Caution.—You have just developed the basic shape of the hull controlled by the outboard edges of the bulkheads. The hull lines of these bulkheads are drawn to the *inside* of the hull planking. The hull lines shown on the profile and the body plan of sheet 1 are drawn to the *outside* of the planking. Consequently, you cannot use the latter to check the shape of the bulkheads but you can use them to check the shape of the hull after you install the planking. The Model Shipways plans were originally developed for a solid hull model, not a P-O-B model. This is a good thing to check whenever you research a set of hull lines. Always try to determine if the lines are drawn to the outside or inside of the planking.

The Sequence to Follow.—From now on it is your choice how to proceed with the remaining framing. Some construction must naturally proceed others in order to avoid building yourself in a corner. Think about what you should do first. You need deck beams before you can install deck planking and gun port framing before hull planking. Enough said.

Bow Framing and Filler Block.—Forward of bulkhead No. 1 a filler block is to be installed to provide a solid area for the attachment of planks and to help define the extreme curved shape at the bow. Glue the block in place as shown on the plans. Next, shape the block so that it fairs from bulkhead No. 1 to the bearding line forward. On sheet 6 you will find a waterline template to aid in the shaping of the filler block. Check the final shape by bending a strip of planking over the block. Does the plank bend smoothly over the bulkheads and filler block into the stem rabbet? Cut and sand until it fits nicely. Work slowly and carefully. Better to remove many small bits of material than a few (too large) bits.

Forward of Bulkhead No. 1 you need a few more bulwark stanchions (or timberheads as they are called) to support the bulwark planks. For the model you are to insert one timberhead and one knighthead into the filler block on each side to provide the missing bulwark supports. See Fig. 9A. A pattern for the two pieces is given on sheet 6. Before gluing the timberheads in place check to make sure they are correctly located. Make a horizontal template, Fig. 9B, for obtaining the correct bulwark curvature. These checks are important so that the planking can proceed later without backing up to correct framing errors.

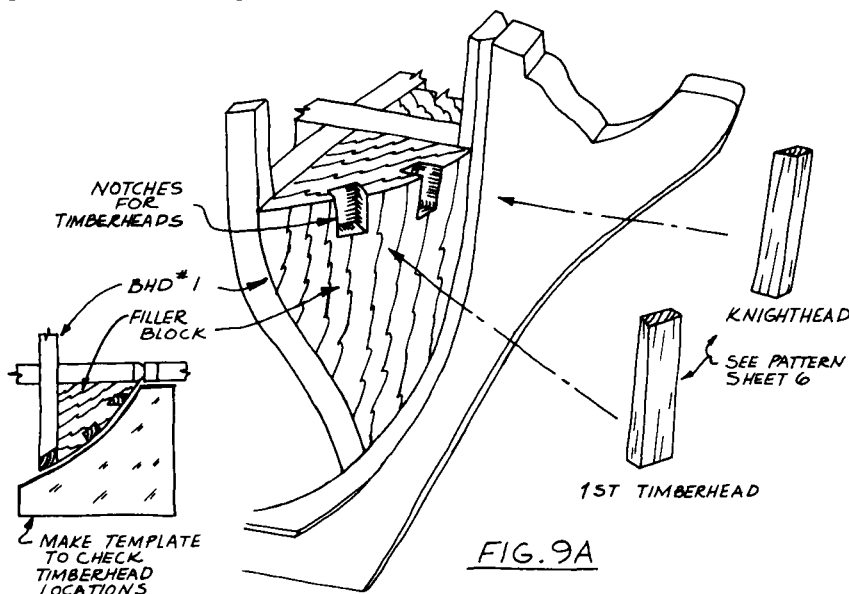

FIG. 9A

FIG. 9B

Stern Framing and Filler Block.—Before installing the filler block at the stern glue the wing transom to the aft side of bulkhead No. 16 and on top of the centerkeel. The pattern of bulkhead No. 16 on sheet 6 shows the locations of the wing transom and the stern frames. Shape the wing transom from the pattern on sheet 6 before installing. After the wing transom is in place add the filler block. There is a little more shape to contend with here than at the bow. Two patterns of templates at buttock lines (vertical), instead of waterlines (horizontal) are provided on sheet 6 to help you check the final shape. See Fig. 10. As with the bow, check the block by using some scrap plank. One difference should be mentioned, however. Much of the plank at the stern aft of bulkhead No. 16, especially at the outboard end of the transom, will require severe bending. In fact you must resort to heat bending. Keep this in mind while checking the shape of the filler block. The shape is not necessarily wrong just because the curvature is severe.

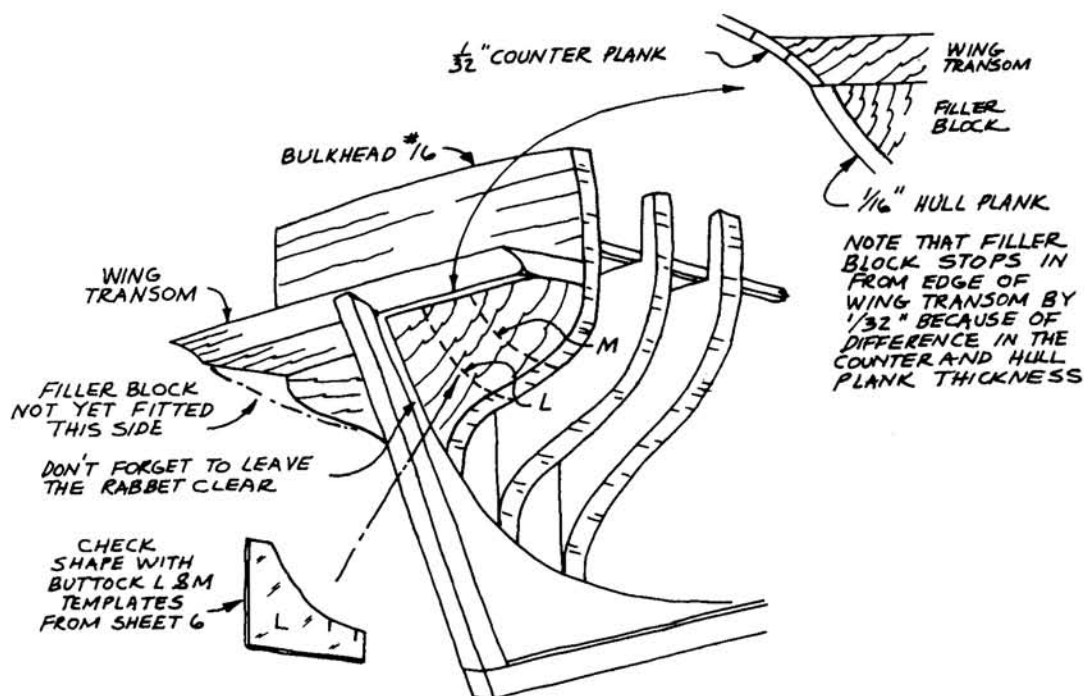

FIG. 10

The stern frames are next. Assemble the machine cut pieces and the after pieces (strips) as shown on the plans. When dry cut the bevels according to the pattern, then glue them in place as shown on the plans. Notice that the two outboard frames (S.F. #1 & 2, port and starboard) are 3/16 inch thick while the others are only 3/32 inch. This extra thickness is required because you must shape the lower corner of the frame and the end of the wing transom slightly to obtain a curve to conform to the hull lines. Thus, some of the frame thickness at the lower, outer edge is removed. Not much shaping is required but it is difficult to tell at this time exactly how the corner should look. However, you will see the shape better and can smooth out the shape later on as you install the wales and black strake. See Fig. 11A. Stern frames #3 & 4 are installed next. They are located on either side of the hull, just inboard of stern frames #1 & 2. Lastly, install stern frames #5 & 6 on either side of the stern post.

After the stern frames are in place and the glue has thoroughly dried proceed to add the other framing members. First, add the transom end pieces on the outboard frames. A pattern for this piece is shown on sheet 6 with the appropriate bevels. Next, add all the planking supports and window frames. When adding the plank supports make sure you do not miss any. Don't forget the piece around the rudder stock opening. Remember, these pieces are necessary so that when the transom planking is installed there will be something there for the planks to land on. This is especially important for ends of planks. Windows can be made completely of wood or use the fittings (cast frames) in the kit. The transom moulding, or cap, is next in line. This needs to be made up of several pieces. See Fig. 11B. Check the transom framing thoroughly and use a sanding block to smooth out the surfaces. You can put off planking for now and go on to other framing areas.

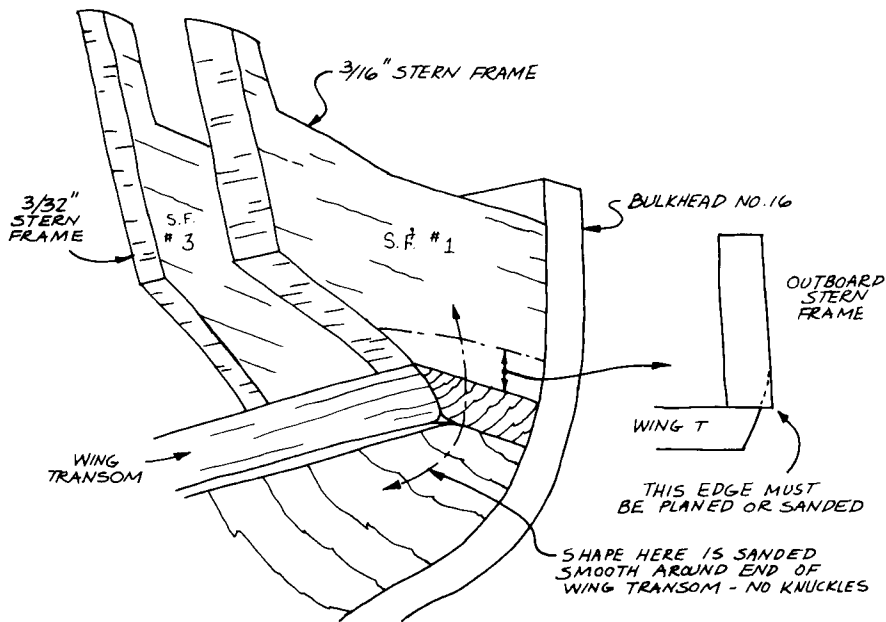

FIG. 11A

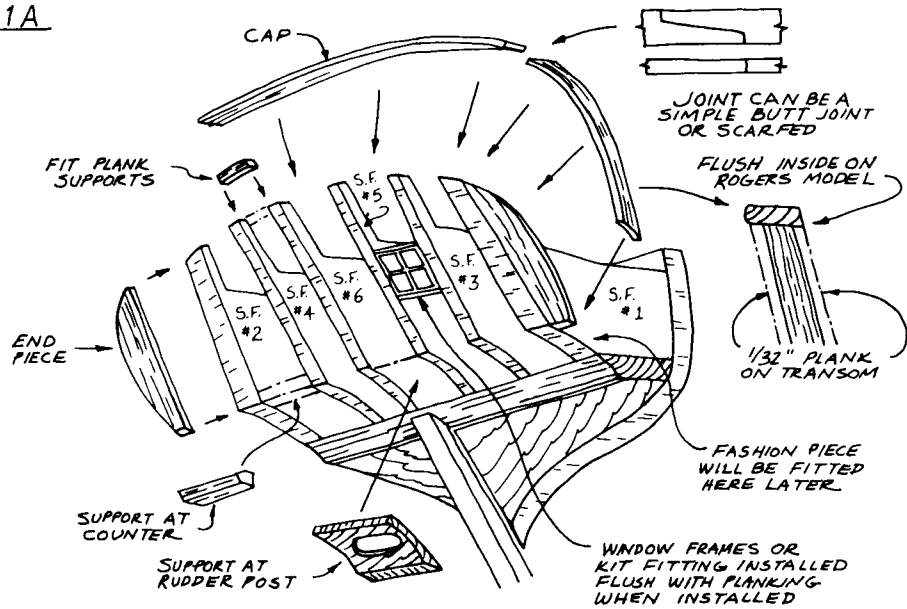

FIG. 11B

Cap Rail and Fancy Rail.—Some modelers may wish to plank the inside of the bulwarks and upper hull prior to installing the cap rail. This is ok if the bulwark stanchions are in line in a nice smooth curve. Adding the cap rail at this time, however, will assure a rigid accurate bulwark prior to planking.

The cap rail can be a straight plank, slightly edge bent, for much of the model aft but as you proceed forward you must cut it from a sheet and add scarf joints. See Fig. 12. Drill a small hole through the rail into several bulwark stanchions and insert a pin or dowel for alignment. While aligning the rail take a small strip of plank (1/32 at the bulwarks) and fit on each side of the cap rail to assure the rail will cover the edges of the plank when installed. A point of note: The plans show the cap rail, and other rails are similar, as built on the Rogers model. The inboard edge of the rail is flush with the bulwark ceiling (inboard plank) while the outboard edge of the cap rail extends beyond the plank and is slightly rounded. The normal practice for a real ship would be to have the cap rail overhang slightly both outboard *and* inboard (a bit more outboard than in). You can make this change if you so desire.

Following the cap rail add the fancy rail aft (excluding the fancy rail cap for now). Notice that the fancy rail stops at bulkhead No. 16. Add a filler piece atop the stern frame and bulkhead as shown on the plans. See the stern pictorial view on sheet 5. Pause for the moment and save the fancy rail cap and the quarter deck rails for later. You need to do some more deck framing before starting these.

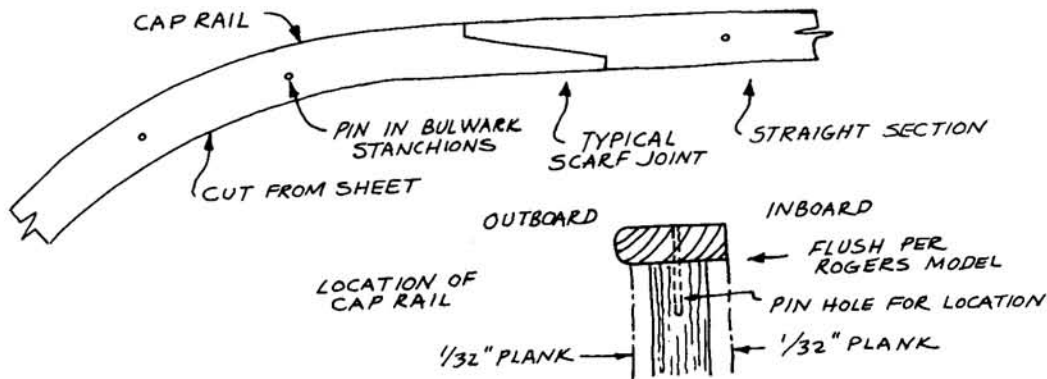

FIG. 12

Waterway and Covering Board.—You may have already installed the waterway instead of a temporary strip to secure the bulkhead spacing as mentioned earlier. If not, now is the time to get these in place. Like the cap rail you will need to cut the waterway and covering board portions near the bow from wider sheet stock. Add scarf joints and glue in place. Bevel the waterway before you install it and round the inboard edge of the covering board. For your information, the waterway is a Model Shipways exclusive. The Rogers model is rather plain inboard and does not have a waterway but a real ship certainly would have. Leave it off and simply use plank if you want to precisely duplicate the Rogers model.

Main Deck Hatches, Plank and Mast Supports.—The kit is designed for see-through wooden gratings. The bulkheads and center keel were deliberately cut out directly below the hatches for this purpose. Paint the areas below the hatches flat black so you cannot see bare wood through the gratings. Cut and miter or half-lap the hatch corners and glue the hatch together before installing on the model. You could also install the grating on the coaming at this time. Glue the completed hatch coamings to the bulkheads. Next, glue the plank supports under the ends of the hatch coamings and under the waterways forward. Another support is required across the deck at the house front. These supports do the same job as described for the transom, they provide a landing for the ends of the deck planking so don't forget any.

Shape some scrap pieces as shown on the plans and glue them on both sides of the mast slots. Test fit the masts in the hole.

Main Deck Aft.—Before building the quarter deck you should decide how you want to treat the main deck aft below the quarter deck. Since most of the area is closed off you need not run the main deck planking aft of the house front. However, as indicated on the drawings you need some support for the gun under the quarter deck. Add some planks or a solid sheet of basswood in the area of the gun. You must also remember to install the gun and paint the area before completely enclosing the quarter deck. Another option is to omit the gun altogether.

Note.—Omitting the guns under the quarter deck may be a most correct decision. Some research material on these vessels indicate that as built these ships may have had a continuous main deck aft with 16 usable gun ports and only a light canopy, or semi-permanent roof over in the quarter deck area. This was peculiar to the Bermuda sloops and Fair American is a Bermuda-type brig. It is believed the house and quarter deck as per the Rogers model may have been added later and at the same time the main deck under the house was lowered to give more headroom. Consequently the gun ports aft could not be used for guns but were left for light and ventilation. Models of Fair American have been built with and without guns in the after gun ports.

Quarter Deck Framing.—Install the quarter deck beams according to the plans. To simplify the work leave the beams flat on the bottom. Cut the deck camber in the top of the beam using one of the bulkhead patterns as a guide. The main deck camber and quarter deck camber are the same. After the camber is cut, cut a bevel for the deck sheer similar to the aft bulkheads at main deck. See Fig. 13A. The beam which butts against the transom must also be sloped on the aft side to fit onto the transom. See Fig. 13B and the profile-at-centerline view on sheet 5. The ends of the quarter deck beams butt against the side of the fancy rail and the outboard stern frames. Make sure you allow space for the deck planks so that the top of the deck plank is flush with the top of the fancy rail before the fancy rail cap is added. The top of the beam at side then should be 1/16 inch below the fancy rail surface. See Fig. 13C. Bulkhead No. 16 takes the place of a beam at that location so no separate additional beam is required. After all the beams are installed fit the house front toeing and vertical stiffeners as shown on the plans. Do not install the great beam at this time. It is best installed during planking of the quarter deck and after the house front plank is completed.

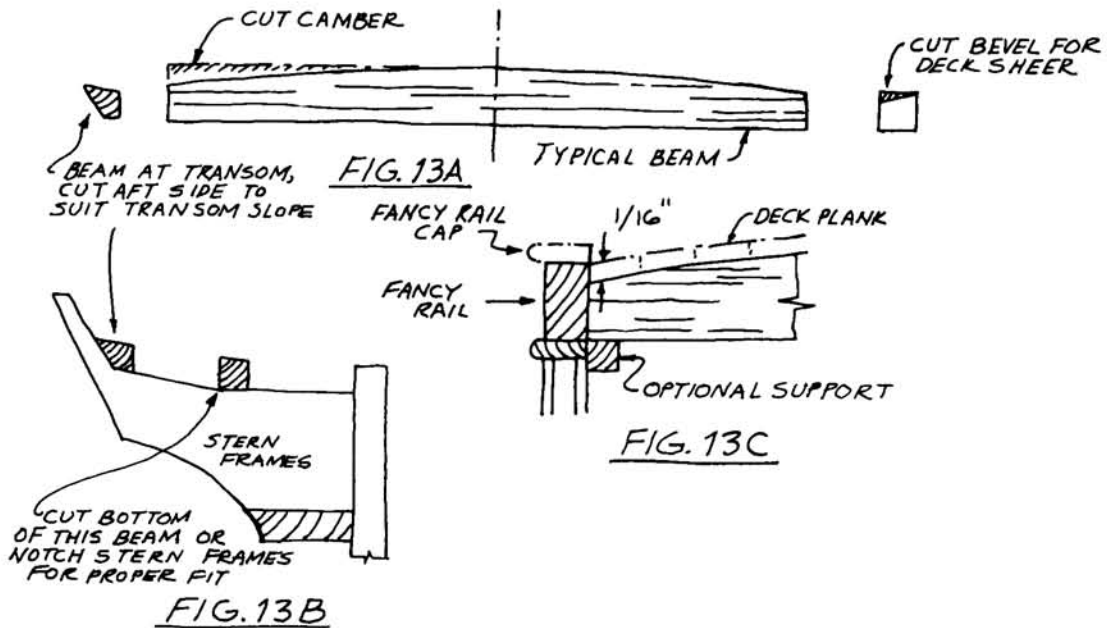

Gun Port Framing.—The gun port frames are best made off the model. Cut the top and bottom pieces slightly longer than the spacing of bulkheads. Add two vertical pieces to frame the port. Make all pieces of 1/8 inch thick wood. Cut the ends to suit the bulkhead spacing and glue in place. Install the framing flush with the inboard faces of the bulwark stanchions. Since the bulwark stanchions taper from 1/8 inch at the deck to 3/32 inch at the cap rail your gun port framing will stick out a little at the top. Use a long sanding block and sand them flush with the stanchions. See Fig. 14.

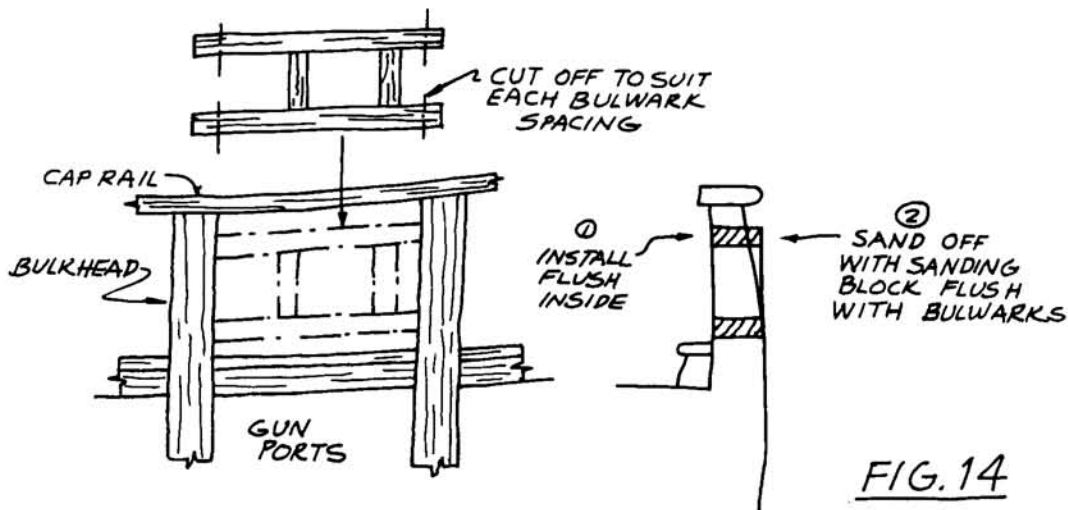

Fancy Rail Cap and Quarter Deck.—Install the fancy rail cap similar to the main cap rail. For the quarter deck stanchions use doweled ends set into holes drilled through the fancy rail. The quarter deck rail cap can be doweled or pinned. See Fig. 15A. The fancy ends of the rail, or hance, can be carved to shape.

Most of the framing is now complete. Check it over before you dive into the planking effort.

Planking.—Now the fun part begins. The kit contains a special booklet on planking which you should follow. Some comments are in order, however, for procedures unique to the Fair American. The booklet is treated as a general text applicable to many types of ship models and will be supplied in other P-O-B or P-O-F kits.

Use the proper thickness planking material: The wales are 3/32 inch, the black strake and lower hull planking is 1/16 inch, the bulwark ceiling and outboard bulwark planking is 1/32 inch, the transom (inboard and outboard) and counter planking is 1/32 inch, the house front planking is 1/32 inch, and the main and quarter deck planking 1/16 inch except for the main deck thick plank from centerline to the outboard side of the deck hatch coamings which is 3/32 inch. These thicknesses are model selections but are equal or very close to real ship scale for this size craft.

The following planking sequence should be followed:

1. House front
2. Transom and counter
3. Main deck thick plank
4. Main deck outboard plank
5. The Great Beam on the quarter deck
6. Quarter deck
7. Bulwark ceiling
8. Wales
9. Black strake
10. Outboard bulwark plank
11. Lower hull

Sheet 6 of the plans shows a planking scheme to help you visualize what the final planks should look like. The widths of the planking for the transom, wales, black strake, bulwarks, decks, and house front are as dimensioned on the plans, sheet 6, and the planking scheme drawing. Most all of these planks have uniform widths forward and aft except for the quarter deck which are curved and tapered but still defined by the drawings. For the lower hull planks below the wales you must develop these yourself. The planking booklet tells you how. While these planks look straight and only tapered toward the bow and stern they are actually composed of side curvature as well. The garboard strake and first broad strake (the first 2 planks next to the keel) should be given a bit more width at the ends in order to follow the curve of the sheer and hull, and to compensate for greater drag, or depth, aft.

Fig. 15B shows a sketch of the transom and hull planking at the stern for clarity of the required installation sequence. Fig. 15C shows some deck plank details peculiar to Fair American.

Notice at the gun ports, outboard only, that the planks are not flush with the opening at bottom and sides. Stop the plank within 1/32 inch of the opening to give a "seat" for gun port lids. This is important even though only one aft lid is actually fitted. In any case, that is what the Rogers model has.

The edges of deck plank can be painted black or dark brown, or use shoe polish, so the seams will stand out to represent caulking after the planks are laid. Careful not to get paint on the plank surface.

Point of Note: Sheet 1 shows the width of deck planks as taken off the Rogers model. The widths, approximately 1/4 inch, appears wider than they should be for a real ship. A note to this effect is given on sheet 5

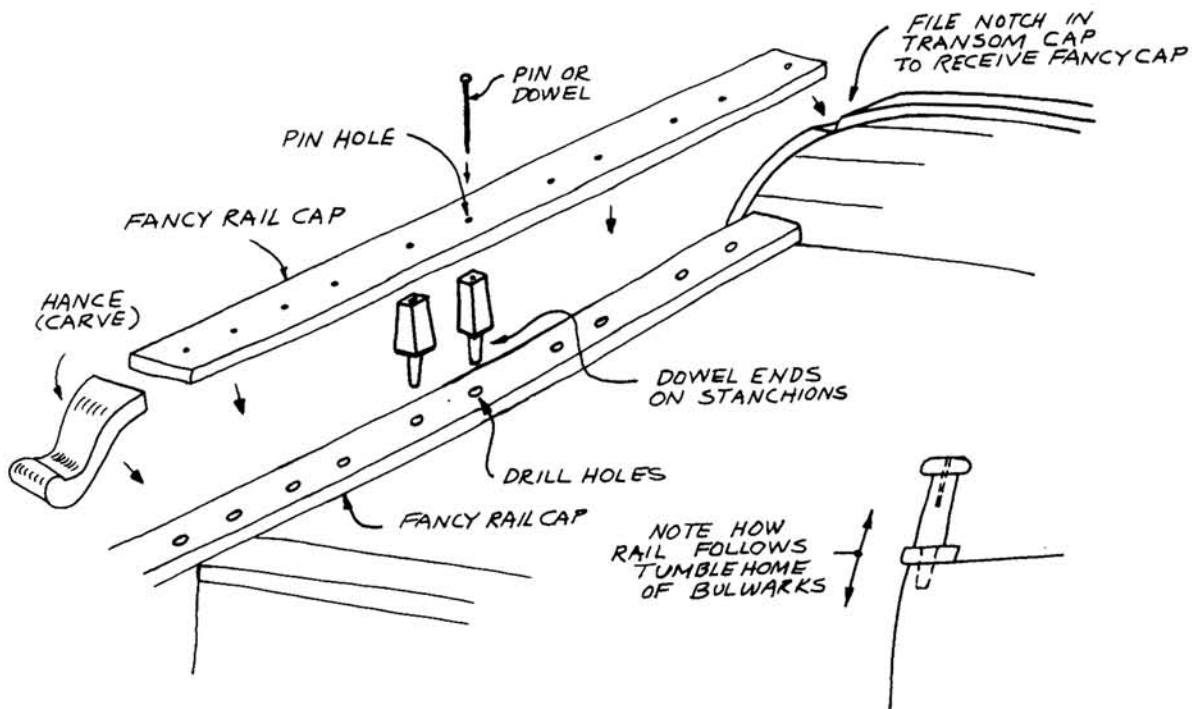

FIG. 15A

suggesting the use of 1/8 inch plank widths which would be approximately 6 inches full scale. Widths of 3/16 inch could also be used and still be reasonable. Most old scantling tables for ships this size indicate deck plank widths around 6 to 8 inches. Your choice.

After all the planking is complete add the fashion pieces at the transom, between the transom and wales, as shown on the pictorial view of sheet 6. Carve these to shape.

Remove any glue squeeze-out and sand all the planking before proceeding. Next add the various mouldings on the transom and house front, then drill holes for scuppers and hawse pipes.

The planking is done. Easy wasn't it! You can now tackle the gingerbread at the stem.

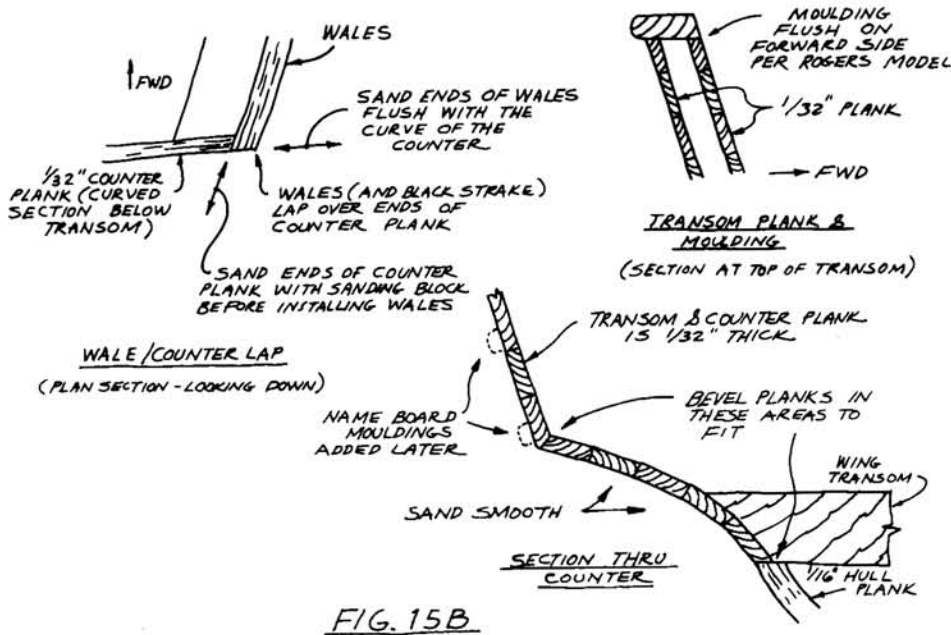

FIG. 15B

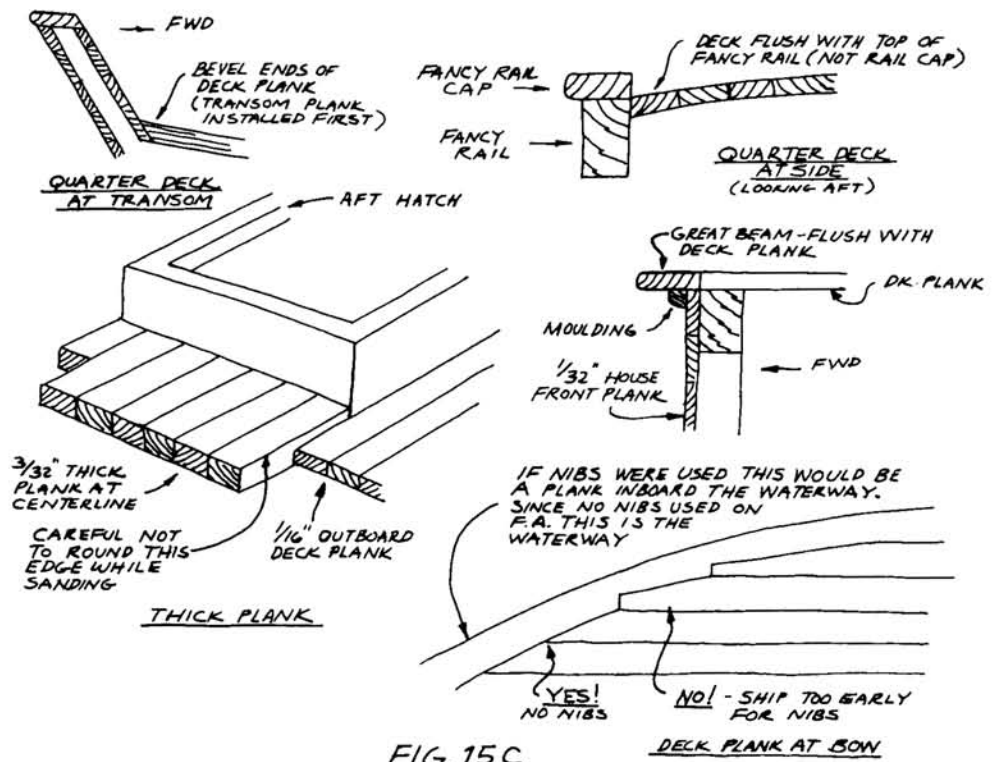

FIG. 15C

The beak head.—Here, we are concerned with making the cheek knees, head rails, head rail knees, and middle rails; they should be fabricated and installed in that order. While perfectly good components can be made from basswood materials furnished, you may wish to try other woods whose combinations of hardness, fine grain, and flexibility or resistance to breakage lend themselves to this work. Boxwood, holly, maple, birch, cherry, or pearwood are all very suitable and one or more should be available at nearby lumber suppliers. Don't forget the possibilities of laminated veneers, wood shavings, cabinet trim veneers, even three-ply birch aircraft veneer. Some modelmakers have even made these parts from brass and copper (easy to bend to exact curves) and soldered the pieces together for a very tough, permanent construction that's easy to finish. Metalworkers, here's your chance.

Begin with making the cheek knees, first cutting them to profile, then finishing them to plan dimensions. Fit them first to the hull; then, if each knee is made in two parts (Fig. 16A), join the roughed-out parts and glue them to the stem. Final shaping of the knees can be done when they are in position, using small half-round files and sanding blocks.

The head rails are next in sequence, their form and dimensions to be taken from the plans, Sheet 1, sheer and deck plans. Note that in the sheer plan, the head rails are not true elevations, but lie at angles to the center line; therefore, their actual lengths are 2", not 1 7/8" and should be increased by 1/8", leaving proportions otherwise unchanged. Note in the deck plan that the head rails are straight when viewed from above, so they can be cut from 1/8" thick flat stock. As seen in the plans, there are bevels in these rails which twist approximately 40° between the catheads and the boomkins; this feature can be ignored in favor of unadorned square rail sections if the modelmaker wishes to simplify matters. Following cutting, tapering, and smoothing, the headrails may be glued and pinned to the bow and the stem knee. Be sure to fit the rails so they go in a straight line to the stem knee when seen from above.

FIG. 16.

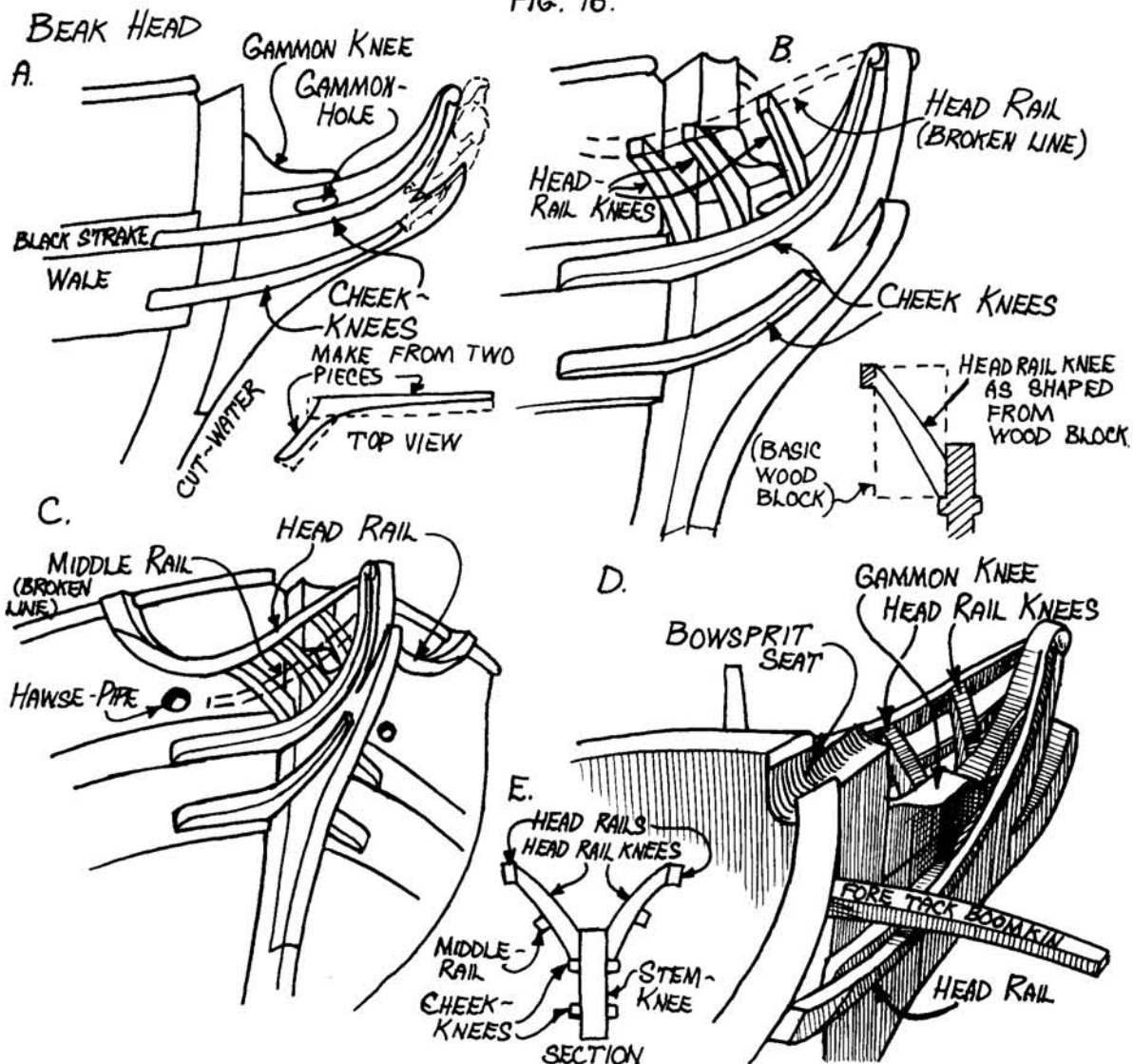

The head rail knees are three pairs of brackets which support the middle—and head rails; their placements are shown in Fig. 16 and they can be measured from the plans. The easiest way to find their dimensions is to make the largest possible block of wood $\frac{1}{8}$ " thick) which will fit squarely between the stem knee and head rail at the proper interval (Fig. 16B). The knee will then be cut from this block, smoothed, and glued in place. Note the spacing and rake (vertical to the waterlines) of each knee.

The middle rails are fitted to the outboard faces of the head rail knees, and are butted forward to the upper cheek knees, and aft to the bow. They are similar to the head rails but with less curvature and can be either bent to shape from $\frac{1}{8}$ " square stripwood or cut to shape from $\frac{1}{8}$ " thick sheet.

Crossing the head rails are the "whiskers", or fore tack boomkins which are made from $\frac{1}{8}$ " square stock. It is advisable to mortise or pin the boomkin heels to the bow, but do not glue them in place yet as they are susceptible to breakage.

Except for the mounting of the figurehead (a carving of your own devising or the metal casting from the fittings package), this completes the beakhead construction. This area should now be carefully primed and lightly sanded. Since this is an important area of interest, you should lavish as much care in construction and finish as your abilities permit. It's not as difficult as it looks on paper, and properly done, the results can be most rewarding.

Channels.—The channels are to be made from $\frac{3}{32}$ " \times $\frac{5}{16}$ " strips to size and form as shown on the plans. Note the cap strips which should not be fitted until the chain plates are installed. Channels should be glued and pinned securely. See Fig. 17.

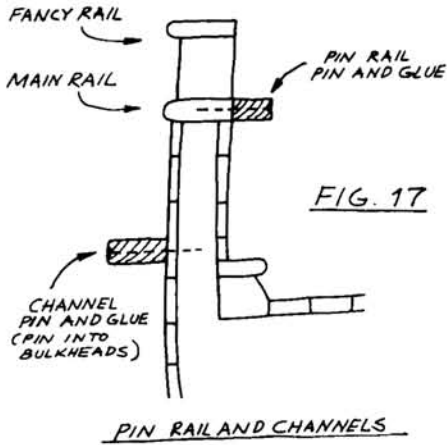

Rudder.—Follow plans for stock dimensions. Fig. 18A, B, and C shows three alternative methods for shipping the rudder. Model Shipways #986 brass strips are suggested for metal straps in any of these methods; the last two may substitute Bristol paper for this purpose. Methods A and B will produce a working rudder which can be unshipped for safe storage during the rest of hull construction; method C will produce a fixed rudder which must be securely pinned to the stern post. The rudder port is shaped as shown in Fig. 18D, making sure it is large enough to allow the rudder head to swing freely inside.

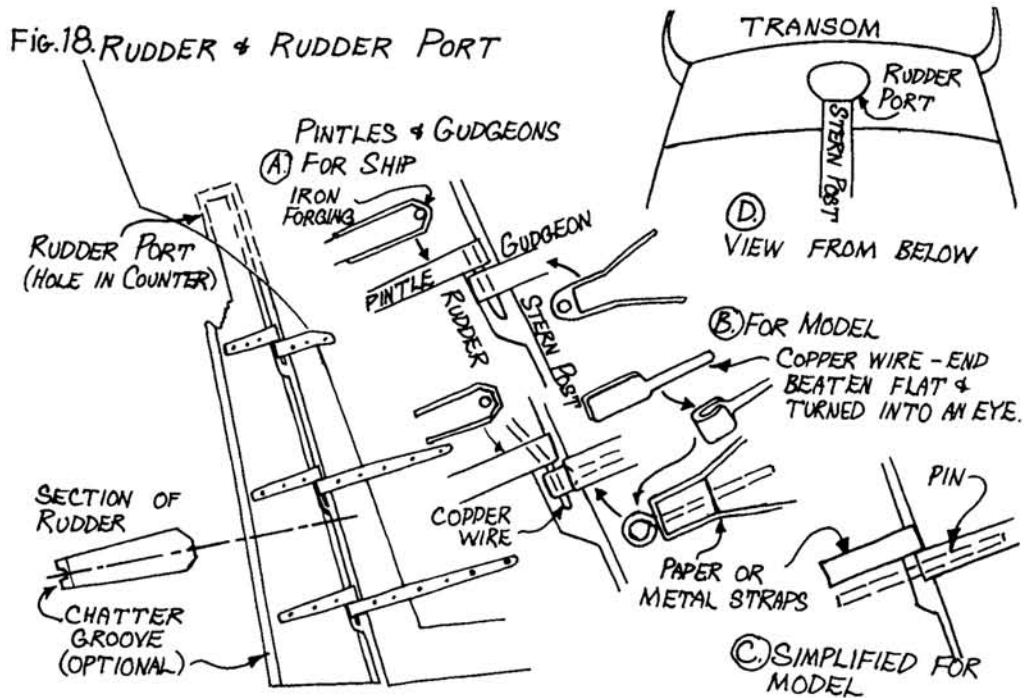

Odds and ends—outboard.—Any remaining outboard details should now be completed: chesstrees, gangway steps, quarter badges (castings provided), eyebolts, bulwark sheaves, fairlead holes, and the after gunport details. The stern lantern may be fitted temporarily, then stored for later installation. Chainplates should be left for installation after the masts have been stepped. Note that gunport covers were **not** fitted to any ports forward of the quarter deck.

Pinrails and bulwark fittings.—The belaying pin rails are pinned and glued in place as shown in Fig. 17. Locations for belaying pins should be carefully marked prior to installation and drilled afterwards. At this time, the bulwarks should be primed, sanded, and painted their final color (see painting instructions). Following painting, all eyebolts for gun tackles and all bulwark cleats are to be installed, the latter being glued and pinned in place.

PAINTING THE HULL

By now, all parts of the hull that are to be painted should be primed and sanded in preparation for the finish coats. There should be no wood defects showing, no grease marks, and no evidence of sloppy brush work. In all subsequent painting, use good quality sable hair brushes, rounds or flats to your preference. The brushes should be fairly wide for most work: #4 rounds or $\frac{1}{8}$ " flats for small or narrow surfaces, #12 rounds or $\frac{1}{2}$ " flats for large areas; for fine detail, use #00 and #0 rounds. Keep all brushes immaculately clean and avoid paint buildup in the bristles near the ferrules. Wash the brushes in soap and water after each day's use.

In applying paint, flow on a film that does not dry in a streaked pattern, nor so thick that it hides detail or sags, forming unsightly "curtains". If you are right-handed, start at the right-hand end of the painting surface and work to the left, making all brush strokes in left-to-right movements. In this way, the trailing end of each brush stroke blends neatly with the starting end of the previous stroke. Left-handed painters should work in the opposite way, starting from left and making right-to-left strokes. If the painting surface is small, you may be able to paint the length of the area in one stroke; try to minimize the number of brush strokes in any event. The above applies to the fast-drying hobby paints, such as Floquil, which are now available in most stores which stock model-making supplies. Users of the more traditional media—lacquers, enamels, and signwriters' colors—should follow painting procedures as recommended by manufacturers and industrial consumers.

Scribing the waterline.—Fig. 19 shows the mounting of the model so its waterline (L.W.L.) is parallel to the baseboard or work table top. A height gauge with a scriber tip is easily made and will make a very useful addition to the modelmaker's tool crib. The mounted model is set on a perfectly flat, smooth surface (a piece of plate glass or formica counter top) and the gauge is drawn around the model, scratching the paint surface lightly with the scriber. Repeat until the mark is easily seen, yet does not chip the primer coat or tear up wood grain. The resulting scribe line will be easy to follow with masking tape or, if you paint to the line freehand, the tiny groove forms a barrier to transgressions by the paint film.

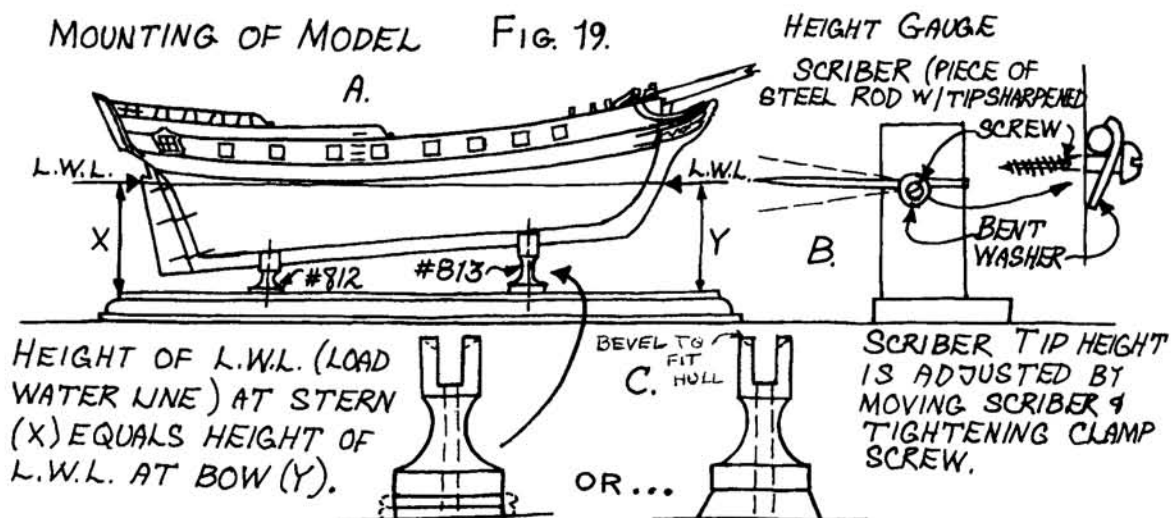

#813 PEDESTAL MAY BE HEIGHTENED BY SOLDERING LARGE BRASS WASHERS TO BOTTOM & FILING FLUSH W/ PEDESTAL BASE (POLISH AFTERWARDS) OR BY MOUNTING PEDESTAL TO A HARDWOOD DISC OF SUITABLE HEIGHT.

Masking tape.—A flexible masking tape such as “Bear” brand (Norton Abrasives) will give a sharp masking line with little or no “bleeding”. The applied tape should be burnished along its edges, using a burnishing tool or the rounded chrome cap from a fountain pen. Masking fine lines can be done with drafting tape such as “Chart Pak” brand, following the same burnishing procedures. *Masking tape should not be left on the model for more than a few hours* and all masking surfaces must be clean (Use a tack rag.). The tape should be removed as soon after painting as possible.

Color scheme.—Based on the Rogers Collection model, the following paint schedule is suggested:

Hull bottom below wales—antique white (Variation: antique white between wales and water line; G.W. cream below water line).

Wales and black strake—black.

Bulwark plank (outboard)—yellowish buff (Mix Mud or Depot Buff with rust in equal parts.).

1 Sheer strake (first bulwark plank below main rail, outboard side)—black.

Main- and fancy rails—black tops, gilt outboard edges, red inboard edges.

Planks between main- and fancy rails, quarter deck rails and stanchions—black.

Beak head above sweep of lower side of main wale—black.

Faces of cheek knees, head rails, middle rails, head rail knees, figurehead, and trailboards—gilt.

Catheads—black above bulwarks; red below.

Bulwarks, inboard—Red (Mix scarlet with a few drops of brown.).

Hatch coamings, bitts, capstan, binnacle, ladders, gun carriages, masts from deck levels to level of rails—red.

Transom—black with gilt moldings and lettering.

Counter—black with red curtains and tassels.

Masts—umber with black tops, topgallants, and poles.

Bowsprit—black outboard; red inboard.

Jibboom—umber with black heel and pole.

Yards, flag staff—black.

Gaff and boom—umber with black ends.

Lantern—black with gilt frames.

Decks, pumps, gratings—natural oiled wood.

MOUNTING THE MODEL

The painted hull should be mounted on pedestals (or keel blocks if preferred) and test-fitted to its finished baseboard. After this dry-run, transfer the hull to a working baseboard (a simple softwood or plywood slab, retaining the pedestals) for sparring and rigging.

A baseboard for display purposes should be made from select seasoned hardwood whose color and grain will contrast pleasingly with the basic form and colors of the model. Since the hull bottom is white with predominantly light colors topside, a dark baseboard will make the hull stand out dramatically. Mahogany is the usual choice as with staining and filling, it can be toned a deep red or a rich walnut color. Other suitable hardwoods might include cherry, walnut, teak, and brown oak; these may or may not require filling and staining. It is desirable to have the baseboard’s dimensions approach the overall dimensions of the model when rigged; this gives the model a more impressive appearance, particularly if the finish has a gloss that reflects the model. In addition, if the model is moved and accidentally hits something, the baseboard is more apt to receive the shock instead of the spars and rigging.

If you are finishing your first baseboard and are receptive to the more recently developed wood sealers and finishes, consult your local paint dealers for advice on what to use and how. With the vast array of exotic concoctions presently available, it is extremely important to select stains, fillers, and finishes which are mutually compatible and do not require exotic application techniques.

For keel fixtures, pedestals such as Model Shipways #812 and #813 are suggested; see Fig. 19A. Alternative mounts would be keel blocks of a contrasting type of wood such as walnut or ebony. Barely visible, and highly effective for that reason, are polished steel pins made from drill rod. Almost any imaginative mounting technique will work if it is well finished, but restraint in the use of gaudy materials or complicated fixtures is recommended. Remember, it’s the model, not the baseboard that you are showing off!

Final inboard details.—All gratings bits, pumps, capstan, binnacle, steering wheel, padeyes, ringbolts, and cleats should be secured to the main deck. Many of these items are furnished as castings which must be cleaned up with files and sandpaper, primed, and painted. The fittings can be glued to the deck with either epoxy or contact cement.

The guns should also be assembled and mounted at this time. See Fig. 20A. The rigging of the tackles and breech lines is optional and these materials are not included in the kit. If you wish to rig the guns, then you should order an additional 5 dozen $\frac{3}{32}$ " single blocks and 3 dozen $\frac{3}{32}$ " double blocks, plus fine cordage and strapping wire. The breech lines, inhaul- and outhaul tackles are rigged as shown in Fig. 20. It is advisable to glue the gun carriages to the deck with contact cement after eyebolts for purchase blocks have been fitted; the gun barrels may be removed after fitting the breech lines and stored away for permanent mounting at a later date. If you decide not to rig the gun tackles, glue the carriages to the deck anyway; they will be a nuisance to install at any later date.

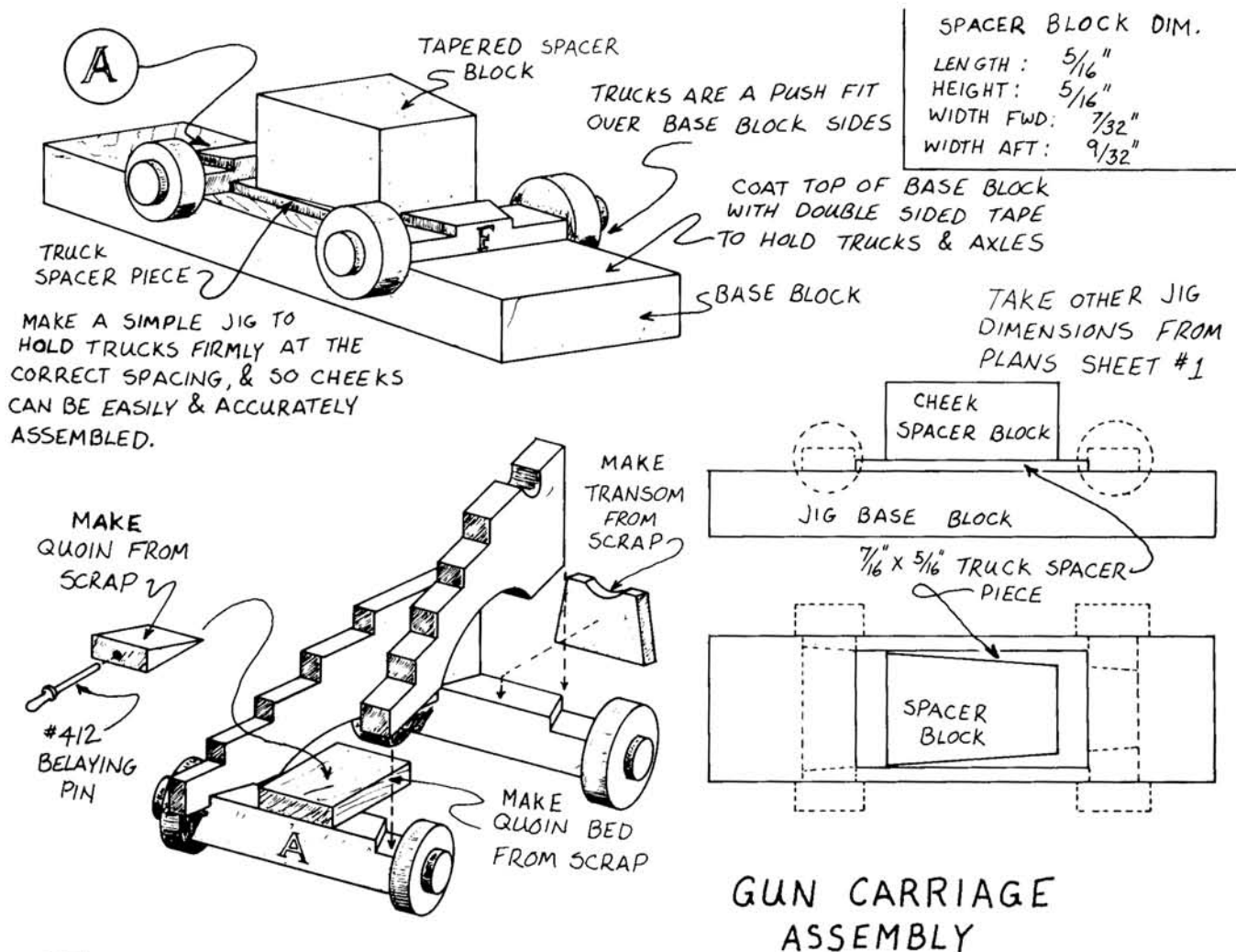
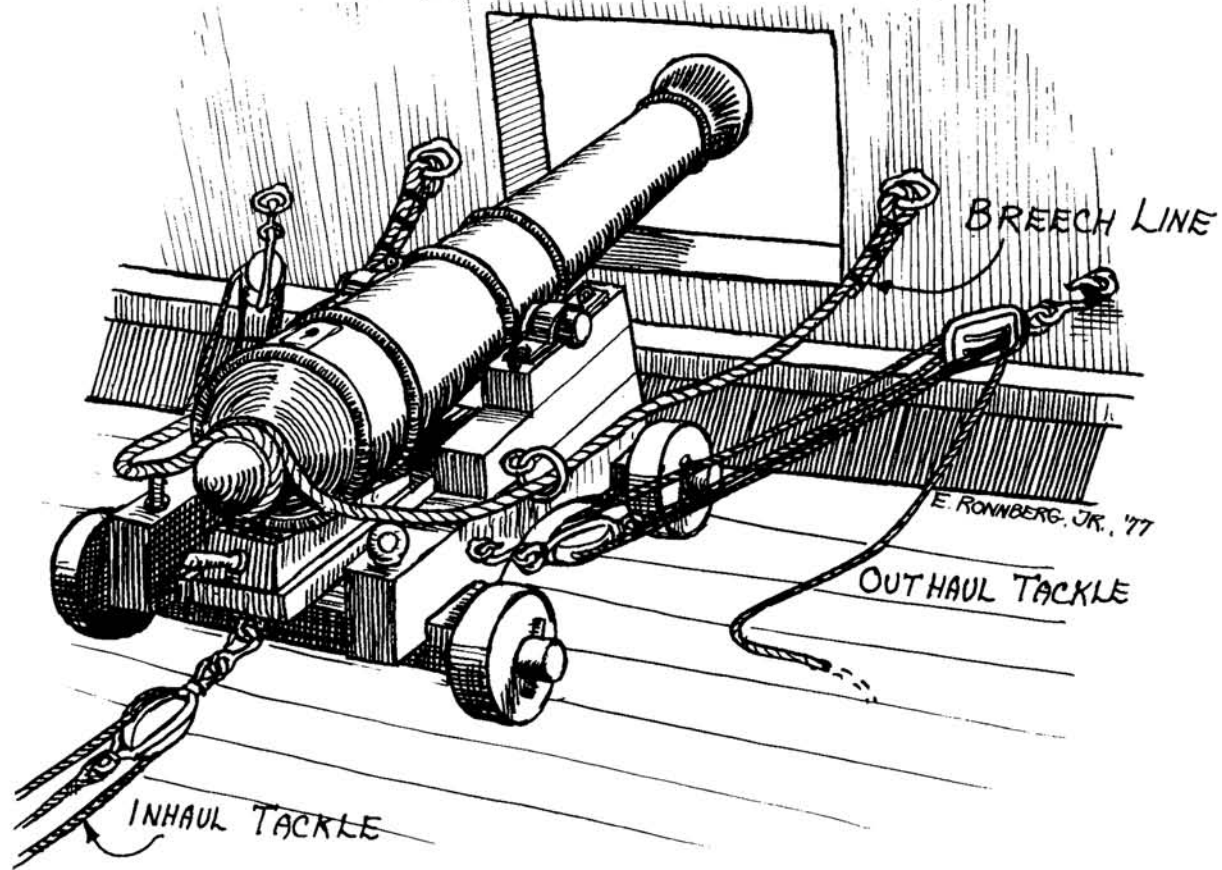

FIG. 20A.

Final outboard details.—The fore tack boomkins should now be securely glued to the beakhead, the stern lantern mounted to the transom, and the gangway stanchions set in the fancy rails. Check for any overlooked ringbolts and padeyes (Check both the hull and rigging plans.) and touch up any imperfections in the paint finish. Your model is now at the stage where the original vessel would have been launched. In colonial times, such an occasion would have been attended by a christening ceremony wherein the vessel was "toasted" with a stiff tot of spirits after she was set afloat. Perhaps now would be the proper time for a similar blessing of your own little ship. Cheers!



MAKING MASTS AND SPARS.

All spars are drawn to model scale in Sheet 2 of the plans. From the dowel stock provided in the kit, match each dowel by diameter to each spar in the plans and label it accordingly. Do not trim the dowels to their exact specified lengths, but leave them about one inch over-length during the tapering process. All of the spars require tapering to some degree and this is best done with a fairly coarse flat file following the sequences in Fig. 21A. If you find yourself tearing up splinters or getting rippled "chatter marks" on the dowels, the file you're using is too coarse; select one with a finer cut. The rounding process is finished with sandpaper, twirling the spars in one hand while sanding briskly with coarse paper. Finish with the finer grades of paper but without twirling the dowels. If you have access to a lathe, this can make the process a lot faster with less risk of "flats" or "egged" cross-sections. With care, spars can be turned by chucking the dowels in a power drill clamped in a bench vise. In the final sanding, it is important to get rid of all cross-grain sanding marks which otherwise will show badly if the spar is to be stained. A well-sanded spar will be glass-smooth with a soft sheen.

After tapering, the spars can be trimmed to their proper lengths. Spar tips are apt to suffer a bit in the tapering process, so it is best to get rid of the last half inch or so at each end. Not all spars are symmetrical in taper; in fact, only the yards are this way. Fig. 21B shows the usual proportions of tapers, but these should be checked against the spar plan to insure accuracy.

After tapering, the heels of topmasts and topgallant masts must be squared by building them up with small wood slabs; use leftover pieces of $\frac{1}{16}$ " basswood sheet. Fig. 21C shows the basic sequence; note that the squaring process in steps 1 and 2 follows the same sequence as Fig. 21A, steps 1-4. The fid holes are squared with a small needle file.

Squaring of the mast heads (Fig. 21D) calls for careful measurements of all flats and confining them to their plan dimensions. The side flats for the bibbs are simply continuations of the mast head flats above them, but they feather out as they descend. The topmast heads are similarly squared but they are not fitted with bibbs; rather, a shoulder must be built up (Fig. 23B) using the method shown in Fig. 22C.

TAPERING SPARS
A.
PROGRESSION OF "FLATS"

START

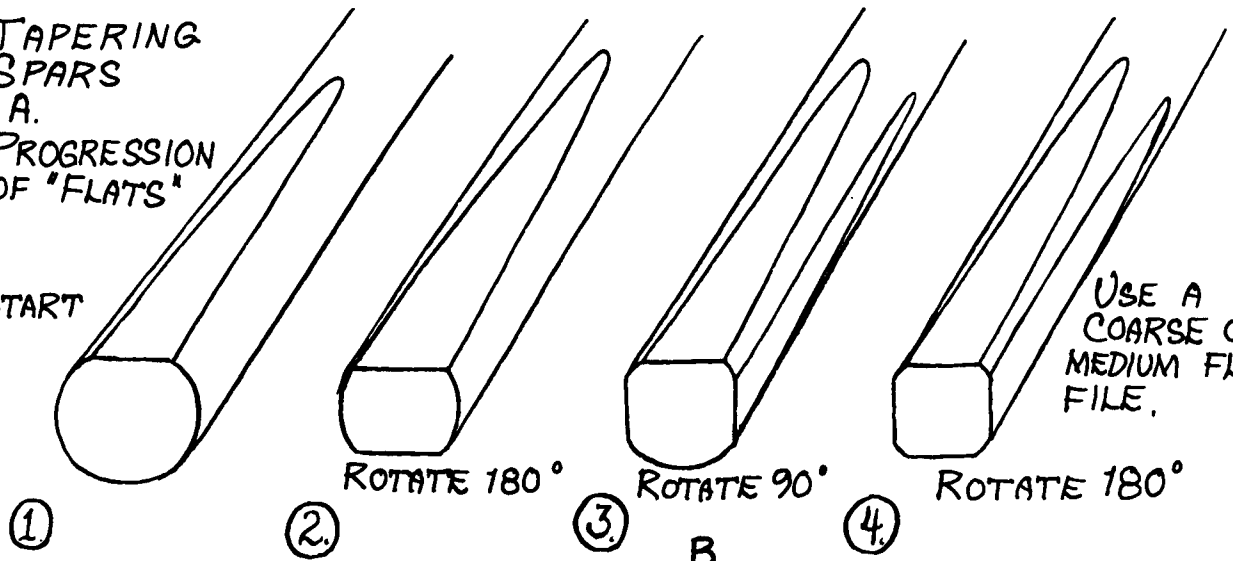

USE A
COARSE OR
MEDIUM FLAT
FILE.

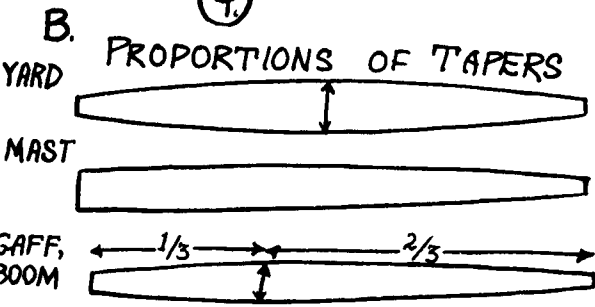
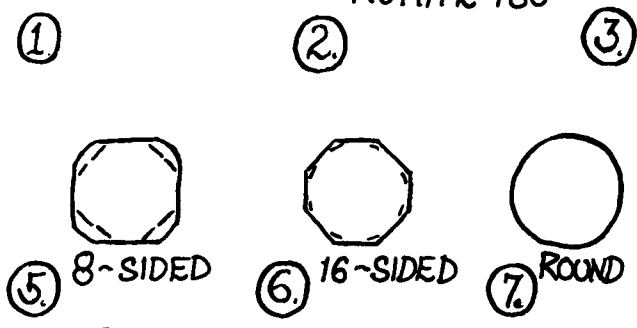

C.
SQUARING MAST HEELS (TOP MASTS + T'GLT. MASTS)

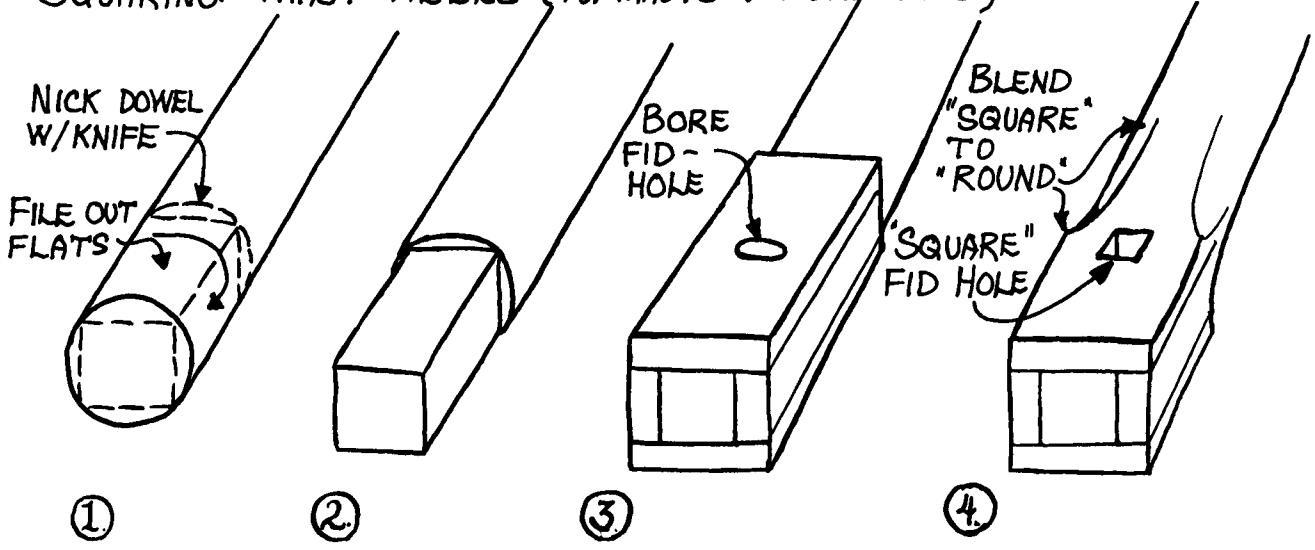

D.
SQUARING OF LOWER MAST HEADS

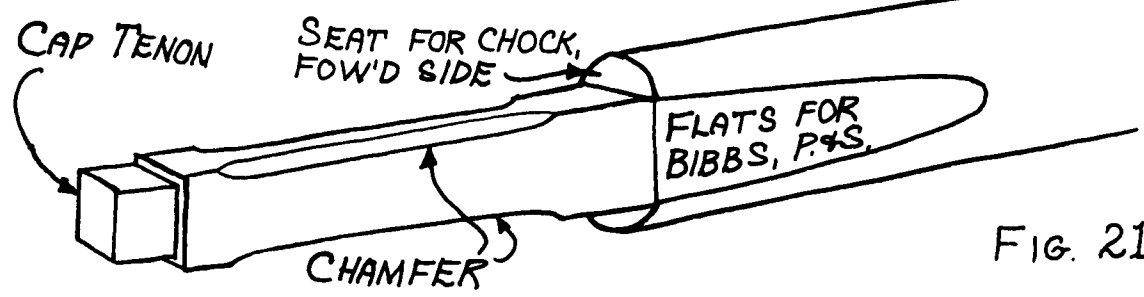

FIG. 21.

YARDS ~ OCTAGONAL SECTIONS

FIG. 22.

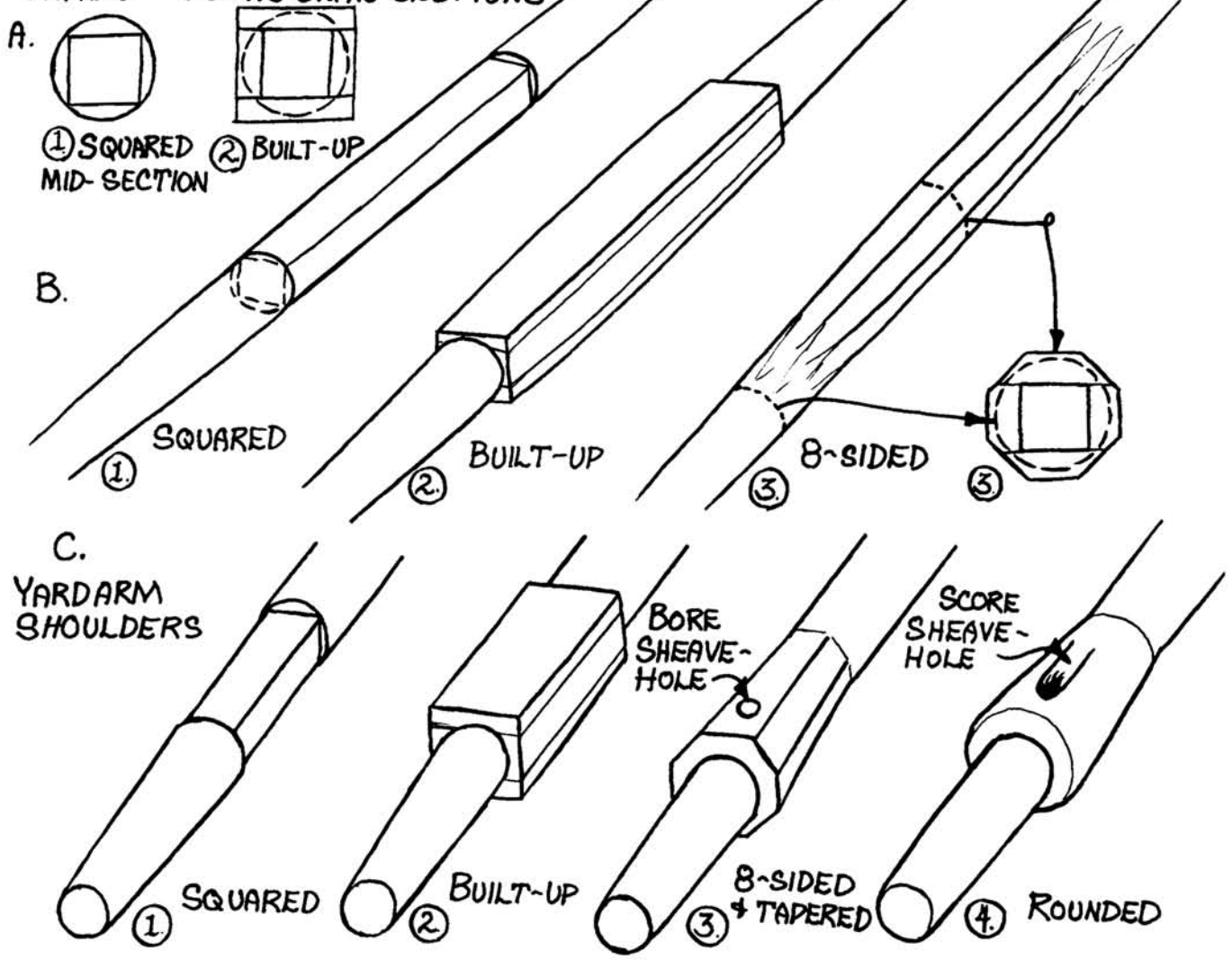
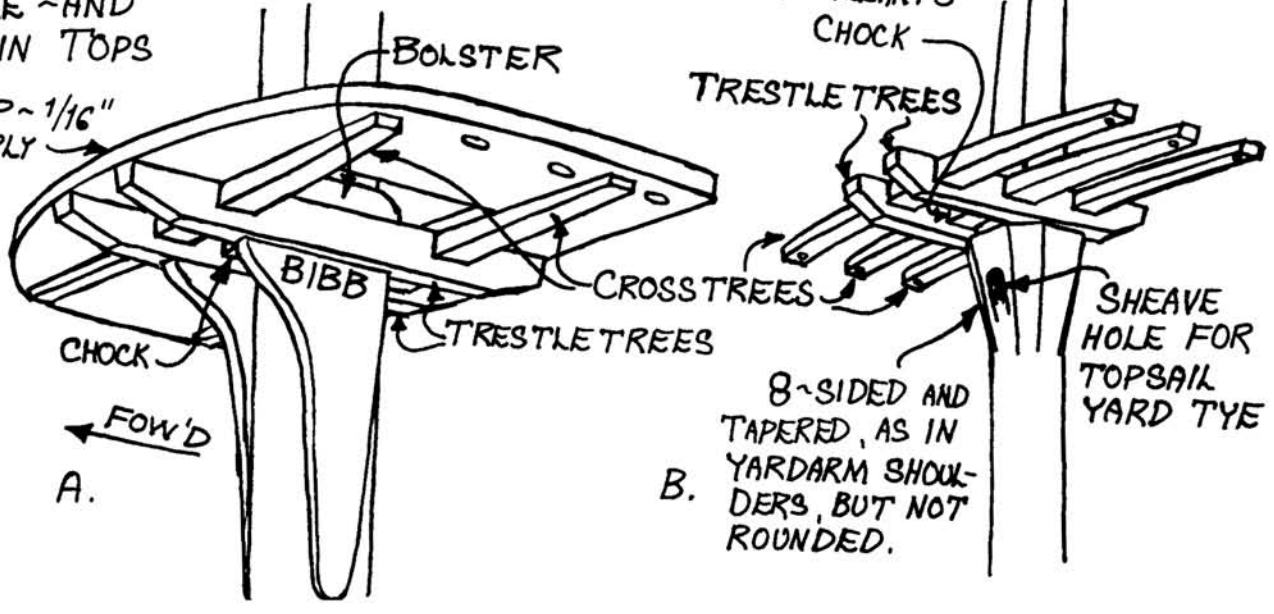

FIG. 23.

FORE ~ AND MAIN TOPS

TOP ~ 1/16" 3-PLY



The lower yards and topsail yards also call for additional treatment if you want to explore the finer aspects of 18th century spars. The middle one-quarter of each of these yards was left in its 8-sided state with the extremities rounded, and if the octagonal sections are to be shown, they must be built up as shown in Fig. 22A and B. This work should be done after the yards have been tapered. At the same time, the heavy shoulders at the yardarms ought to be built up in similar fashion. After piecing and gluing, the mid-section is tapered in its 4-sided state, followed by 8-siding and careful blending into the round parts. Sheave holes at the yard arms are first bored out, scored with a fine-pointed knife blade, the scoring then being smoothed out with a round needle file.

Having tapered all spars and added all squared ends and 8-siding where necessary, you can now attend to the smaller details. Begin with cleats for yards and the main gaff, then bowsprit details, gaff- and boom jaws, and trucks. The bowsprit- and mast caps are included in the fittings set, though it may be preferable to make your own. Alternative caps can be made from hardwood such as birch, maple, or boxwood, or try one of the numerous sheet plastics available, such as Plexiglas or Lucite.

This leaves the fore and main lower tops and the topmast crosstrees to deal with. Laser cut wood tops are provided, but you will find they require detailing. The topmast crosstrees will have to be entirely scratch built. You should begin by fitting the laser cut bibbs, tapering them as shown in the spar plan. Next, assemble the laser cut trestletrees, and the crosstrees and chocks which have to be made from scrap timber. The dimensions of the crosstrees can be taken from Plan Sheet #2. When the assembled trestletrees and crosstrees have been correctly fitted to the mast, the top can be located and glued to them, making a single unitized top construction. The chock which sits between the trestletrees forward acts as a spacing block for the topmast heel which keeps the topmast's center axis parallel to that of the lower mast.

Fig. 23A shows the top assemblies as they should look at this stage; primed and sanded smooth, they are painted black. The topmasts crosstrees are similarly constructed, minus the bibbs and the decking. The crosstrees may be sawn or steamed to shape, preferably from hardwood such as boxwood, birch, or perhaps best, from bamboo split from an old fishing pole, or from chopsticks. Before fabricating them, you should get the lower mast caps over the topmast heads; otherwise, the caps must later be split and glued together around the topmasts. The heels of the topmasts and topgallant masts may now be fidded and the major mast elements assembled. Fig. 24 shows how the topmast heels lie in the tops.

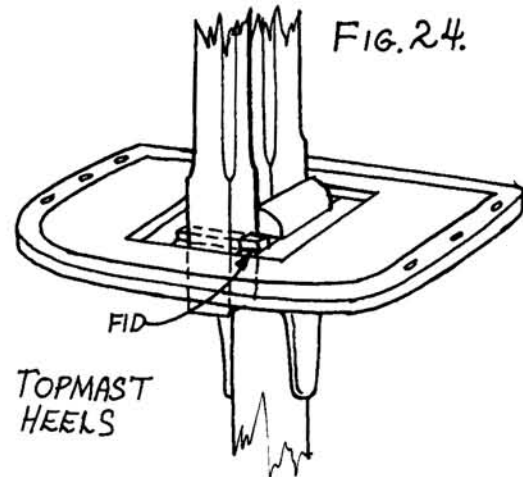

In all aspects of model sparmaking, preparation of surfaces for finish work is of paramount importance. Each piece must be sanded glass-smooth and free of any imperfections before assembly. Primer coats and stains are one-shot applications; any mistakes will show and are often impossible to correct. In cases of painting, two finish coats are probably all that will be allowable; it will be impossible to sand many inaccessible areas between coats, hence the need for careful preparation. Use a frisket knife (X-acto #4 or #9) to scrape or flick off any dust or wood particles painted into the surfaces.

RIGGING

Your model's rigging falls into two categories:

1. **Standing rigging**—For supporting masts (shrouds, stays, backstays), standing parts of tackles, such as pendants, also footropes, standing lifts, and slings. Standing rigging was heavily tarred; its color should be a very dark brown, almost black. Black cordage is provided in the kit and standing rigging is shown in the rigging plan in black print.

2. **Running rigging**—For trimming spars and sails, hoisting, reefing, and furling. Running rigging was the tan color of untarred (or very lightly tarred) manila or hemp; white cordage is furnished in the kit for running rigging.

Cordage.—The rigging line supplied in this kit is cotton, black for standing rigging, white for running rigging. This material will prove quite serviceable for the less experienced modelmaker; however, the seasoned veteran will probably want to make substitutions, using Cuttyhunk linen, which comes in a wider variety of sizes and will last longer. A table of rigging diameters is given at the end of this booklet for those who wish to scale the rigging as accurately as possible. If using micrometers appeals to you, here is a very good opportunity to use one.

KNOTS FOR SHIP MODELS



OVERHAND KNOT

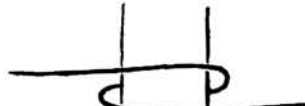

A ROUND TURN



TWO HALF HITCHES



SQUARE KNOT

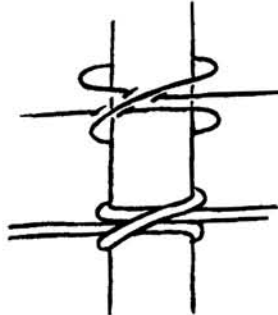

CLOVE HITCH



FIGURE-EIGHT KNOT



TWEezer ACTION
TWEezERS
TWEezer HOLDER ~
WOOD BLOCK w/HOLE



GROOVES FILED IN
TWEezer TIPS

EYE-SEIZINGS

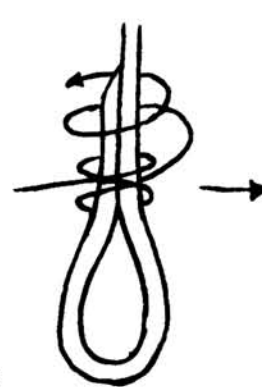

4 ROUND-TURNS



FINISH END w/
HALF-HITCHES

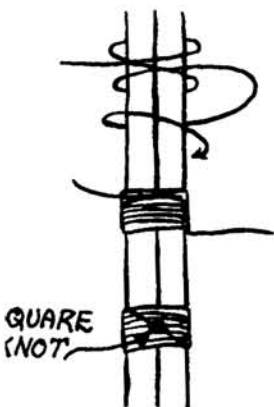

SHORT SEIZING

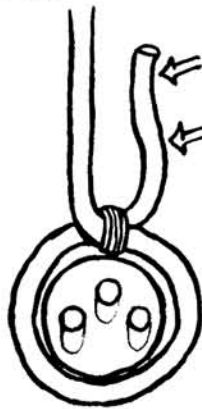

THROAT SEIZING

FINISH
w/SHORT
SEIZINGS

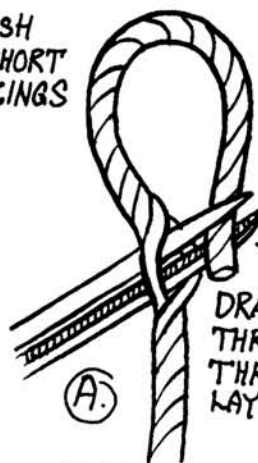

(A)



(B)

REPEAT
& SEIZE
w/GLUE.

A "FAKED"
EYE SPLICE

FIG. 25.

Generally speaking, when selecting the size of thread for a given member of the rigging, it is better to err on the small side. Many beautifully crafted hulls have lost their looks of realism because of a heavy, clumsy-looking rigging job.

Tarred rigging.—Stockholm tar was the usual preservative for standing rigging and it was dark brown, almost black, in color. Mix burnt umber and black in equal parts and you will have about the right shade. Some riggers added turps and black paint to the tar to harden it and give it a rich, glossy black which had a very handsome appearance.

In tinting standing rigging, it is suggested that you try a thin paint—Floquil, japan colors, or thinned enamels. Avoid a “jet black” color; even blackened tar had a slight brownish tinge to it. A little gloss will not hurt either, for it accentuates the lay of the rope or serving and imparts depth and “life”. This can be done to the Floquil paints (which are dead flat without additives) by mixing in a little “Crystal-Cote” prior to painting. When dry, rub down the rigging by drawing it through your fingers; this will eliminate any fuzzy appearance due to loose thread fibers.

Cordage.—Running rigging of this period consisted mainly of manila rope, a very supple-fibered cordage that ran smoothly through blocks and was easy to handle. New manila rope was a golden straw color which tended to bleach on exposure to sun and salt water. Manila running rigging was seldom, if ever, tarred, and would rot out quickly if oiled. Depending on your tastes, this rigging can be tinted to resemble new stuff or old and can vary from a rich tan to a silvery weathered gray. Cotton cordage, as supplied in the kit is too white and must be dyed; linen thread from the spool will simulate bleached rigging well, but its color can be deepened to simulate new rope.

To dye this stuff, you can use any one of the commercial dyes for fabrics available from stores dealing with yard goods. Avoid dyeing the thread in tea or coffee; the tannic acids in these brews will rot out the most durable of natural fibers. Paint will stiffen thread and oil stains will rot it; however, “Flo-Stains”, made by Floquil Paints, will work, but they must be thinned or the line will be tinted too dark. Maple “Flo-Stain” is about the right color.

Perhaps the best tinting for thread is liquid wax shoe polish. There are several different brands offering brown polish in varying shades and tones which can be mixed with neutral polish to obtain a lighter shade. In using these polishes, you are not only tinting the thread, but you are also coating it with preservative which will extend its life. When dry, draw the thread through your fingers and this will lay down any surface fuzz and add a mild sheen which adds life to the line’s appearance.

Knot tying.—If overscale rigging doesn’t spoil a good model’s appearance, clumsy knots and seizings certainly will. Fig. 25 shows a variety of knots, hitches, seizings, and simulated splices which are essential for neat, strong rigging details. You should practice tying all of them, using your left hand to steady the thread, or to “feed” cordage; your right hand to manipulate or guide the thread end, using tweezers as needed. Practice tying all of these until you can do them without fumbling or looking at these instructions for assistance! Bear in mind that the neatest knot work will come to naught if the cordage you’re using is overscale. Seizings should be made with the finest thread you can find, but **not** nylon monofilament which is too slippery and won’t take glue or tinting readily; however, stranded nylon thread is quite satisfactory.

Scaled cordage.—If you use the cotton cordage supplied (Four sizes black, two sizes white) plus any finer sizes of thread obtained in a sewing goods store, you will have to approximate many rigging sizes, going by the old rule that the higher aloft the rigging leads, the smaller the cordage size. In practice, the rigging plan shows the standing rigging in different sizes, so the simplest thing to do is to match the kit cordage as closely to the plan sizes as possible. For running rigging, the heavier size cordage should be confined to mast- and stay tackles, throat and peak halyards, and other heavy running rigging specified in the rigging tables at the end of this book. The finer white cordage will do for lower yard- and topsail yard braces, halyard whips, etc., but the topgallant running rigging may look best if the finer sizes of sewing thread are used.

Linen cordage.—For those who want museum grade rigging, linen has yet to be surpassed for its durability and ship-shape looks. The rigging tables in this book give a list of cordage sizes to kit scale. Be sure to match your linen to the cordage diameters in the rigging tables. When rigging with linen, it is generally not advisable to use other kinds of cordage (cotton, nylon, etc.) on the model, due to their differing habits of shrinkage and expansion which can result in some odd-looking rigging leads. Linen can be tinted and waxed as described previously. Most of the linen is 3- or 4-stranded with a distinct rope-lay, making it possible to put in miniature splices and achieve detail and realism not easily attained with other types of cordage.

Stepping the masts.—The fore and main masts may be stepped temporarily assembled or the job can be done piecemeal, beginning with the lower masts and rigging, followed by topmasts, topmast rigging, etc.; this is simply a matter of personal preference. The lower masts must be stepped at their precise angles of rake (derived from plans) and must not “lean” to port or starboard. If, as suggested previously, you have bored oversize mast holes,

you can adjust the angles of rake very easily by setting tiny wedges around the masts at deck level. The heel of each lower mast can be prevented from shifting by driving a head-less wire brad into the end grain (pointed end down) and then driving the heel pin into the bottom of the mast hole. Crude but effective.

Fitting the chainplates.—This task has been delayed until now because it is essential to have the masts stepped in order to determine the slant of each shroud (or backstay) and its corresponding chainplate. Following the procedure shown in Fig. 26, mark the position of each chainplate on the channels, notching the latter to receive the chainplate straps. A string may now be used to project the slant of each shroud to where its chainplate is to be fastened to the black stake. This should be done carefully—slight deviations will be noticeable—and the chainplate hole marked and drilled (#75 drill). Strap the deadeyes with the #439 strap rings and trim each chainplate, bending the upper end into an open eye; when the deadeye strap is hooked to the chainplate, close the eye. Set these assemblies into their respective notches in the channels and cap the latter with stripwood as shown on the hull plan and Fig. 26B. The chainplates may now be pinned to the back stakes. Paint the deadeyes, straps, chainplates, and channel caps; touch up the bulwarks and wales if their finish was marred in this process.

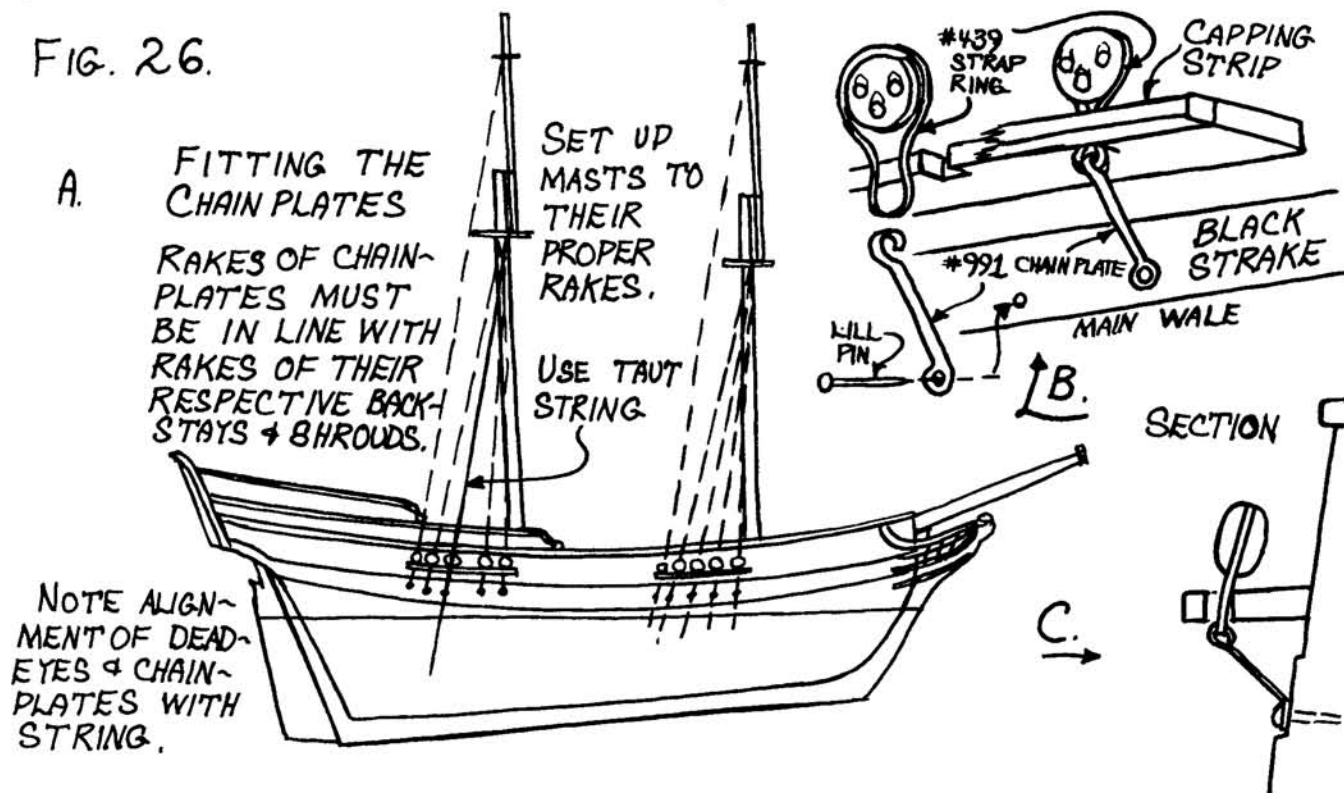

The bowsprit and gammoning.—The bowsprit is seated between the knightheads with its heel socketed to the bowsprit bits. Since there is no preventer chock at the knightheads to hold the bowsprit down to the rails, the gammoning and bowsprit must be relied on to hold this spar in place. Those who wish to secure the bowsprit as firmly as possible can glue or pin it at the knightheads. The gammoning is rigged as shown in Fig. 27, using medium black cordage which has been heavily waxed. Draw all turns around the bowsprit tightly and finish as directed.

Serving.—As you will notice in the rigging notes, many items of the standing rigging were covered with a protective twine called serving. This prevented chafing from sails and moving parts of the running rigging; it also prevented crushing of rope fibers when the shrouds, stays, etc. were placed one over the other around the mastheads.

On the scale of this model, serving is possible to do with very convincing results, and a few perfectionists will undoubtedly want to add this nicety to their models. Fig. 28 illustrates the basic principle of serving; the serving mallet (for manual use) is very simple to make and the only other necessity is any sort of contrivance that will stretch taut the cordage to be served. Most serving on this model is over short lengths, so it is not necessary to mechanize this process. If you plan to do extensive serving work in subsequent models you might consider making a serving accessory to your lathe or jury-rigging a serving machine using an old sewing machine motor. This matter has been discussed in several advanced books and journal articles on ship modelling.

Any fine sewing thread, such as stranded nylon or polyester, will make excellent serving twine; tinting can be done after serving, and it is advisable to coat the completed service with a clear flat lacquer or flat varnish. Service ends are started and finished with several hitches which are set with white resin glue.

BOWSPRIT GAMMONING

FIG. 27.

① START AT BOWSPRIT

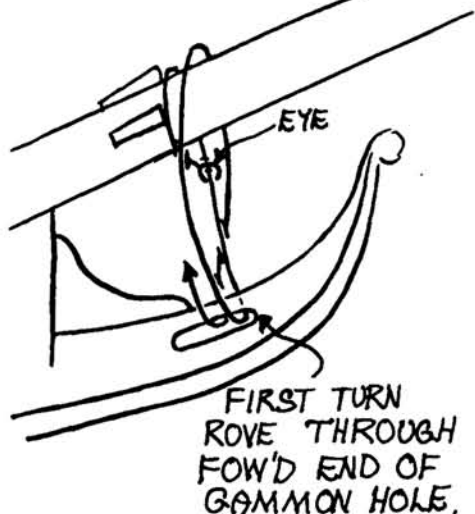

② MAKE 9 TURNS

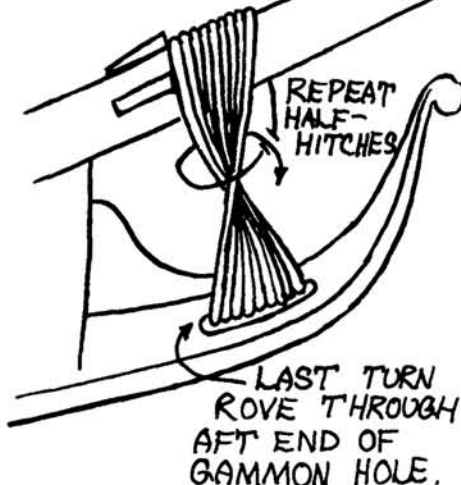

③ CROSS-SEIZING

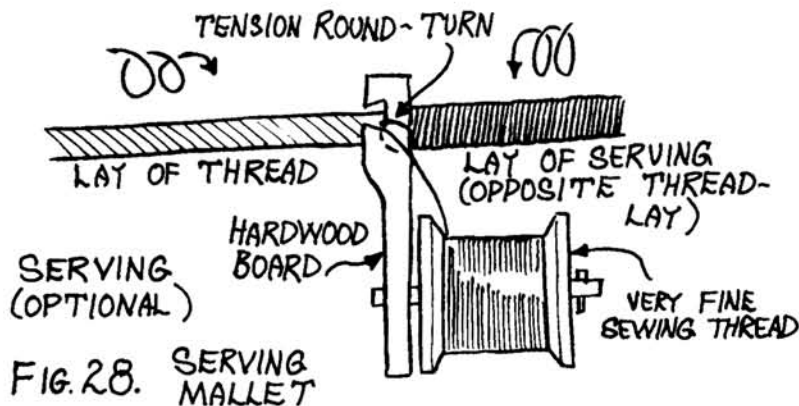
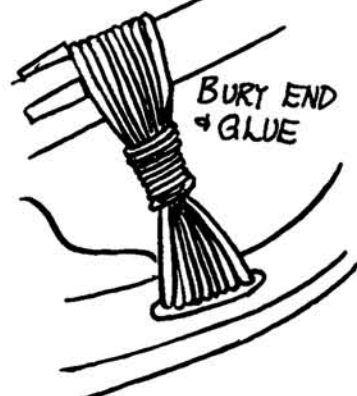

Bobstay and bowsprit shrouds.—The bowsprit is supported outboard by two shrouds (one each side) and a bobstay from below. The bobstay is seized at its lower end to a hole in the stem knee; it is set up with deadeyes and a lanyard at the bowsprit. The bowsprit shrouds are hooked at their inboard ends to eyes in the main wales; the outboard ends are set up with deadeyes and lanyards as was the bobstay. Deadeyes at the bowsprit are seized into collars as shown in Detail D on the rigging plan. These collars go around the bowsprit and are tightly set up by lanyards. The bowsprit shrouds and bobstay are seized to their deadeyes as shown in Fig. 29B and Detail B in the rigging plan. When setting up the lanyards, hitch the larks' heads, but do not glue or trim them until later when the lanyards have stretched out.

Rigging the lower masts.—All cordage for the fore- and main mast tackle pendants, lower shrouds, and stays should be prepared for rigging in that order. The correct lengths of the mast tackle pendants should be scaled from the plans; shrouds and stays should be cut over-length to insure adequate scope for seizings. The lower shrouds are seated over the mast tackle pendants, beginning with the first starboard shroud pair, then the first port, followed by second starboard and second port. Leaving the mast tackles to be rigged later, the shrouds should now be set up with deadeyes and lanyards. Starting from forward with the first-seated shroud, from a loop in its lower end and start a throat seizing (Fig. 25). Before tightening the seizing, work it into a position where, when the deadeye is inserted, the loop can be pulled snug around it at the correct distance from the lower deadeye. The correct spacing of deadeyes can be scaled from the rigging plan; note also in Fig. 29 the appearance of correctly rigged deadeyes and lanyards. When the throat seizing has been tightened and set with glue, finish off the rest of the seizings for that shroud and trim its end neatly. If you have trouble maintaining uniform spacing of upper and lower deadeyes, try using a "deadeye claw" as shown in Fig. 29C. There are variations on the design and construction of this little gadget, should you have inclinations to tinker with it.

DEADEYES & LANYARDS

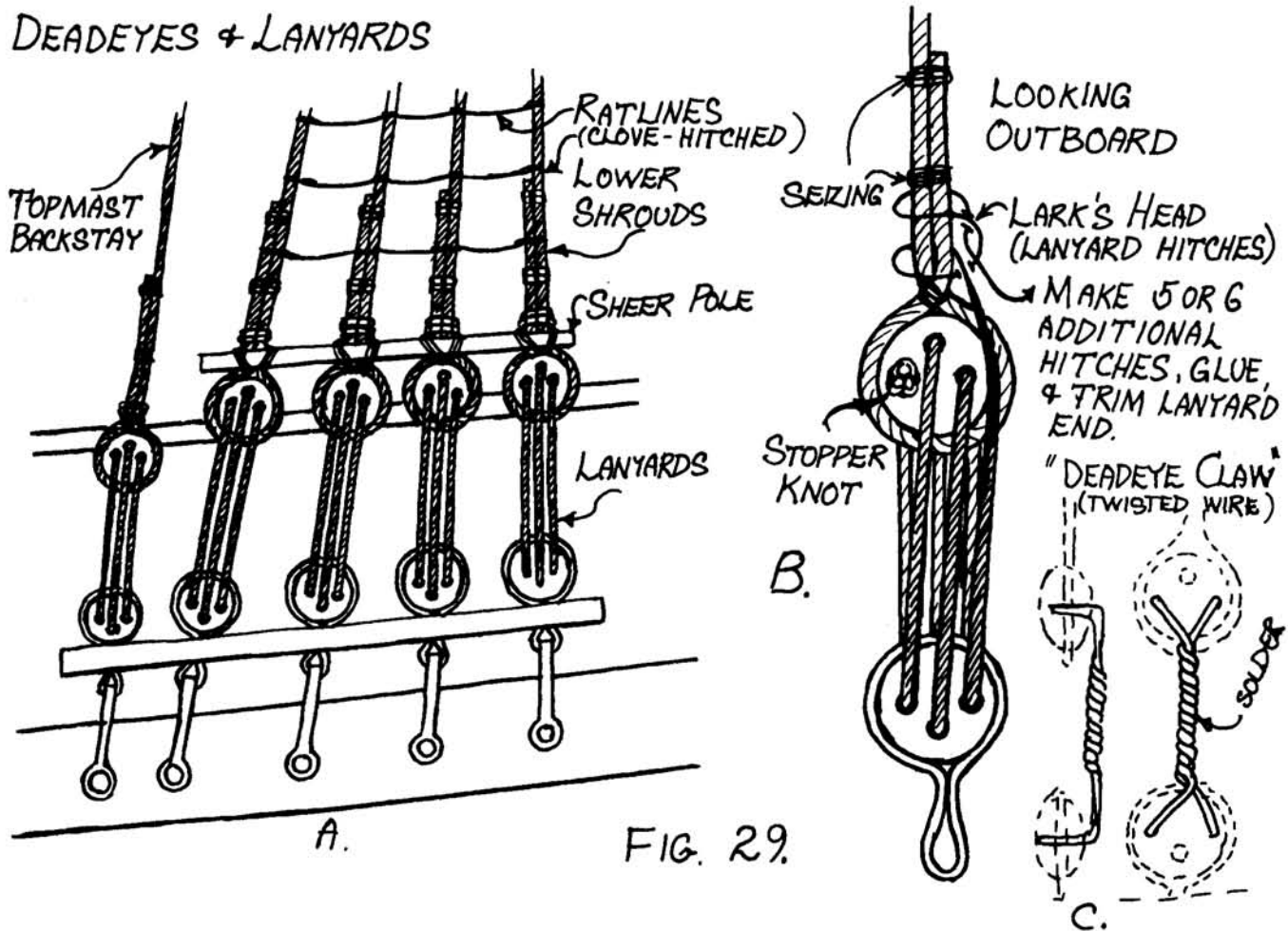

FIG. 29.

With the first deadeye seized in, reeve off the lanyard (Use a figure-8 knot for a lanyard stopper.) and set it up as shown in Fig. 29B, but make the lark's head temporary for later adjustments. The above procedure is repeated for the remaining shrouds in the same order as they are seated at the masthead. In setting them up, beware of pulling the masts out of line; taut shrouds are desirable, but don't overdo. Before rigging the sheer poles and ratlines, allow the shrouds to settle in and stretch for a few days. In the meantime, you can be busy with other elements of the standing rigging or in fitting out the yards.

Sheer poles and ratlines.—Sheer poles (Fig. 29A) are best made from tough, stringy wood like bamboo and cut to $\frac{1}{32}$ " square in section. Cast off the larks' heads on all shrouds of one side, glue a sheer pole in place, seize it securely, and re-hitch the larks' heads, setting them up for the last time, glue, and trim. With all sheer poles in place, proceed with the ratlines.

Ratline stuff should be of very fine sewing thread; do not give in to the urge to make these lines appear prominent in the standing rigging. Heavy ratlines will look very clumsy on your finished model, and if anything, slightly under-scale ratlines will have a more realistic appearance. Hand-in-hand with this problem is that of tying the ratlines to the shrouds: **clove hitch** them! It's not that hard to do (See Figs. 25, 29.) and this model is blessed with relatively few of them, so do the job right. Remember that ratlines lie parallel to the horizon (Use the model's waterline for reference.) and they are spaced 15" apart to scale. Avoid drawing the shrouds together with ratline tension. One way to alleviate this is to pull each ratline's ends apart firmly before trimming; each segment should "sag" slightly between the shrouds. After each side's ratlines have been tied and adjusted, all clove hitches should be touched with thinned white resin glue and thread ends cut when dry. Finally, tiny wooden cleats should be seized to the shrouds as shown in Fig. 34. Use hardwood and glue the cleats to the shrouds before seizing.

Fore- and main stays.—These are the heaviest lines in all of the standing rigging; the main stay has in addition a lighter preventer stay which is used for setting a staysail. These stays' upper ends are secured around the mastheads and to themselves by means of a terminal eye and "mouse" as shown in Figs. 31, 32, and Detail C in the rigging plan. Several ways of "raising the mouse" are shown in these drawings and it is up to the modelmaker to choose his method; chances are, if you've omitted serving in your model's rigging, the method in Fig. 32 won't justify the effort required.

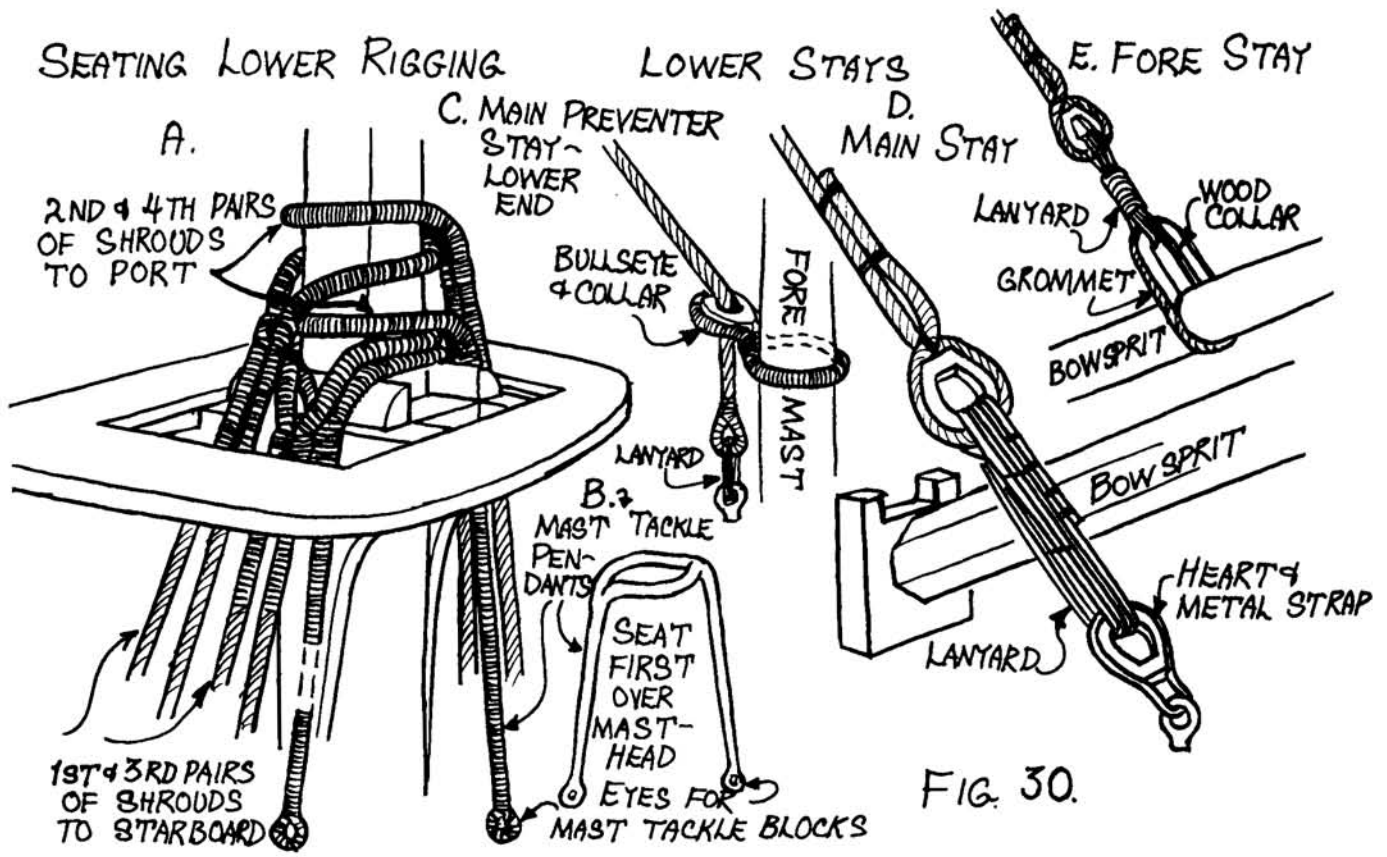

SIMPLIFIED MOUSE FOR STAYS

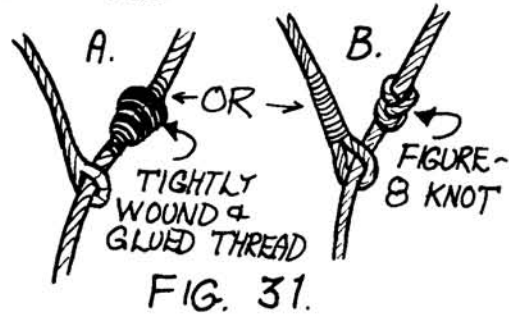

A MORE ELABORATE MOUSE

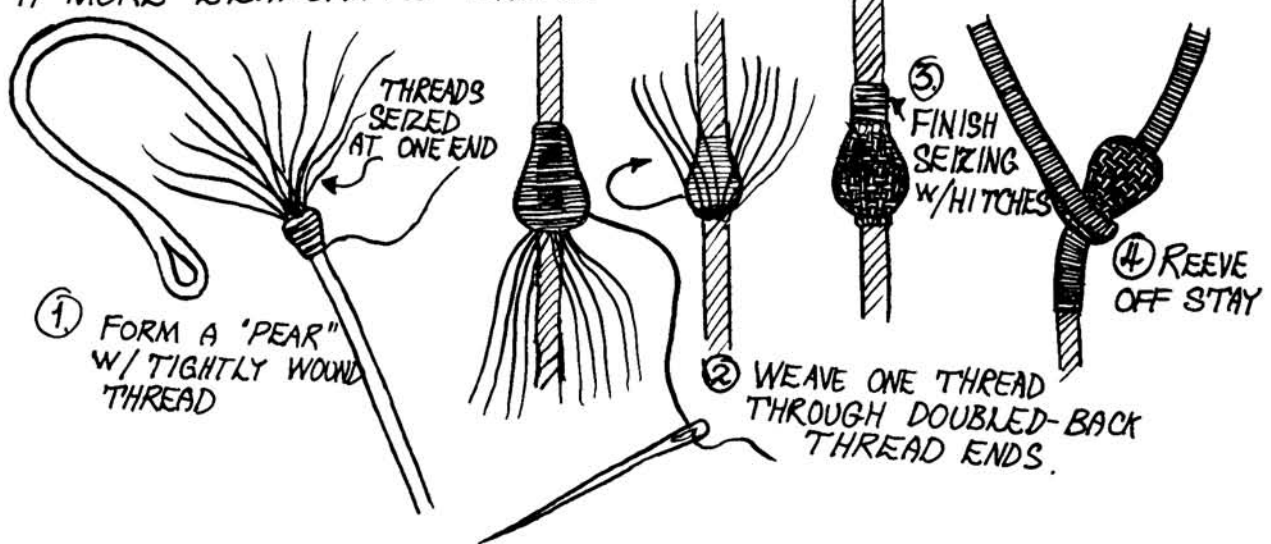

The stays are seated carefully over the shrouds and led forward to their respective set-up points on deck. The main preventer stay is first seated and set up with eyes and a lanyard, via a bullseye fairleader on the aft side of the fore mast (Fig. 30C and Detail M in rigging plan). The main stay is seated over the preventer stay and set up with hearts and lanyard on deck in the "eyes" of the vessel; this is shown in Fig. 30D and in the rigging plan, Detail E. The fore stay is seated over the fore shrouds and set up on the bowsprit with a heart, lanyard, and bowsprit collar, the last being carved from a piece of hardwood like birch, boxwood, or bamboo; see Fig. 30E and Detail N. The tension on these stays should be carefully adjusted so the masts are not pulled out of rake.

Topmast rigging.—The rigging of the topmasts follows similar procedure: burton tackle pendants first, followed by topmast shrouds, topmast backstays, finally the topmast stays (Fig. 33). Again, delay rigging the burton tackles and set up the shrouds and backstays as you did the lower shrouds. The upper ends of the topmast stays are the same as their lower counterparts, but their leads below are different, as can be seen in the rigging plan; more on this later.

FIG. 33.

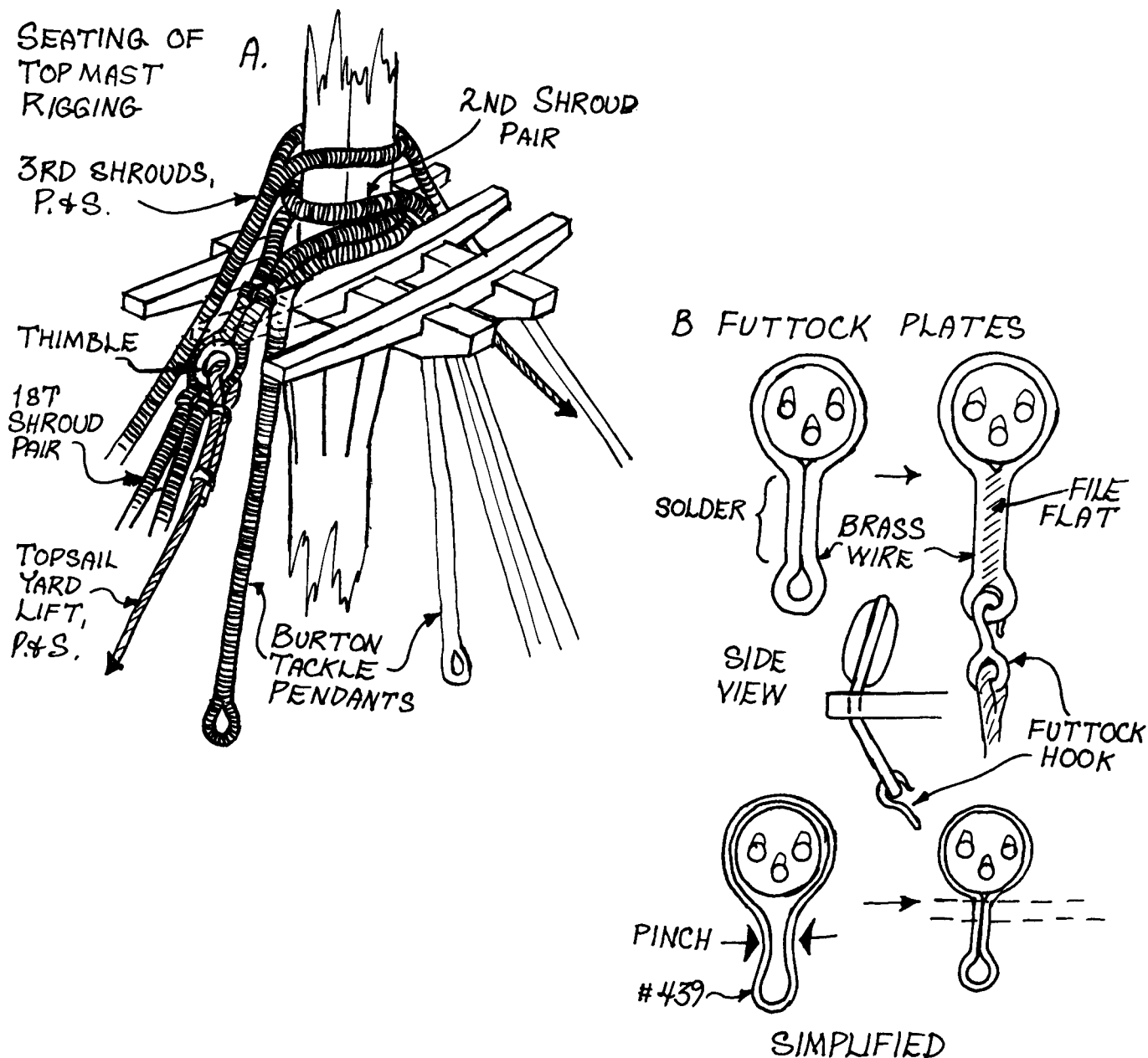

Before setting up the topmast shrouds, you must first rig the futtock shrouds and their attendant hardware. The lower deadeyes of the topmast shrouds must be strapped to form a futtock plate (Fig. 33B) which pierces the top and terminates in an eye to which the futtock shroud is hooked. Detail G in the rigging plan shows how futtock shrouds are seized to the lower shrouds; the futtock stave is $\frac{1}{32}'' \times \frac{1}{32}''$ hardwood, similar to the sheer poles in form and function. Futtock shrouds should be rigged very taut, enough to start the lower shrouds slightly; their ratlines are rigged as elsewhere.

When the topmast shrouds are set up and “rattled down”, the backstays may next be rigged, followed by the topmast stays. The main topmast stay is rigged over the main topmast head as were the lower stays; however, its lower end is rove through a $\frac{1}{4}''$ single block at the fore mast head (Detail I in spar plan) and is seized around a fiddle block halfway down the aft side of the fore mast. A purchase is rove between a single-becket block on deck and the fiddle block, the hauling end being hitched to the deck block at its strap.

The fore topmast stay is doubled, seized, and seated over the topmast shrouds and backstays; its two parts lead down to the bowsprit where the ends pass through the bowsprit bees, to port and starboard. The stay ends are seized to fiddle blocks and purchases are rove off as shown in the rigging plan; the hauling ends are rove through fairlead holes at the knightheads and hitched to the bowsprit bits.

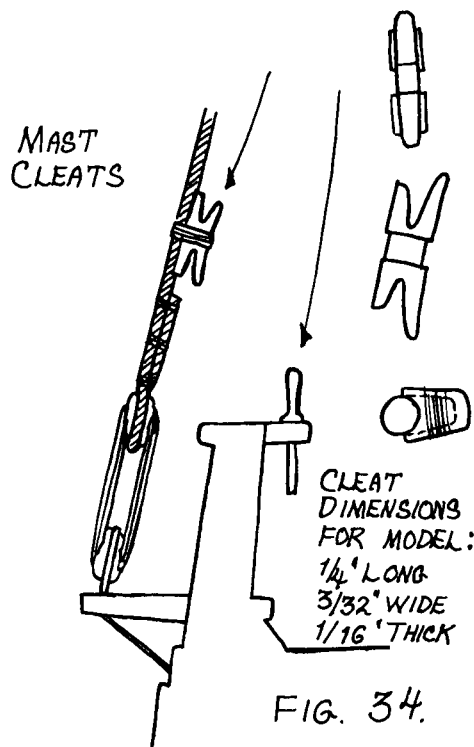

FIG. 34.

The jib stay is a single stay with a large spliced eye at its upper end which is seated on thumb cleats at the mid-point of the fore topmast head; its lower end passes under an outhaul ring, through a sheave in the jibboom, and is set up to an outhaul tackle under the jibboom (See Fig. 35.). The outhaul tackle is belayed to the pinrail in the bow (See belaying pin plan.). An inhaul is seized to the jib stay outhaul ring, led aft, and belayed to the outhaul tackle's belaying pin.

Topgallant rigging.—The fore and main topgallant shrouds are first to be made up. The shroud eyes should fit snugly on the mast shoulder; the lower ends pass through holes in the topgallant crosstrees and are set up to the topmast shrouds in fashion similar to the lower futtock shrouds, minus the staves. The topgallant shrouds have no ratlines.

The topgallant backstays are seated over the shrouds; however, they are not set up with deadeyes and lanyards, but with runner tackles which are shown on the rigging plan.

The fore and main topgallant stays are similarly fitting with small eyes at their upper ends and fit snugly over the mastheads. The lower end of the main topgallant stay is fitted with bullseyes and lanyards and is set up to the aft side of the fore topgallant, where the masthead bullseye is strapped with wire and hooked to an eyebolt in the aftermost crosstree. The fore topgallant stay leads down to a block at the end of the jibboom and aft to the bow pinrail where it is belayed.

Mast-, stay-, and burton tackles.—These purchases were used for loading and unloading cargo, getting boats aboard or overboard, sending heavy gear aloft, and on occasion, setting up the rigging. The mast- and burton tackles are rigged both port and starboard; their parts are shown in the rigging plan and listed in the rigging tables. The stay tackles are single units and are similarly described. These tackles should now be rove off, hooked, and belayed as shown in the plans; rigging the stay tackles should be temporary, however, as they are apt to get in the way of subsequent rigging operations.

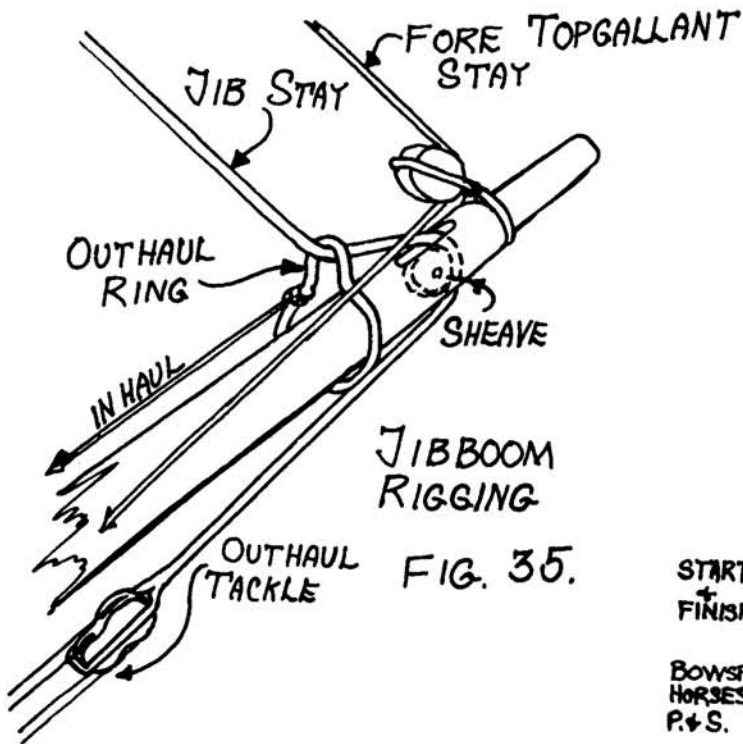
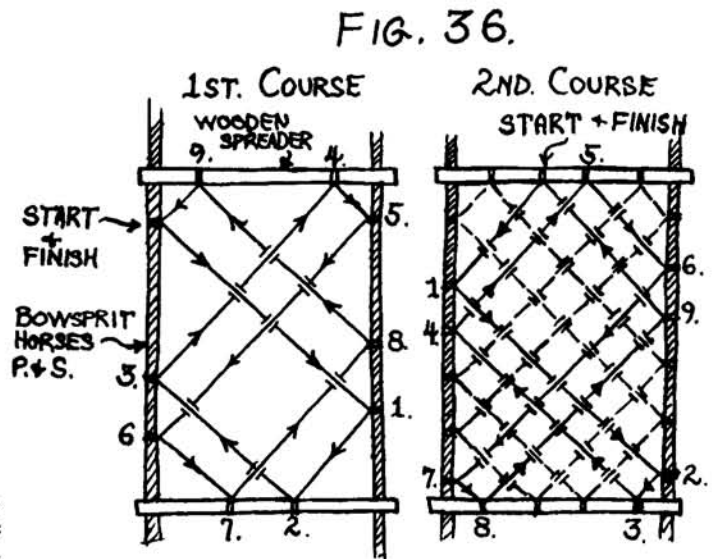

FIG. 35.

Bowsprit horses.—Rigged port and starboard, these are lifelines for crew members working on the bowsprit. Shown on the rigging plan as Item #5, they are seized to eyebolts in the bowsprit cap and set up with lanyards to eyebolts in the knightheads. They are supported at their mid-points by a stirrup rigged from the fore stay. At their forward ends, the horses are fitted with two wooden spreaders and a net which was used to furl and stow the jibs. Fig. 36 shows how this netting can be simulated, using very fine sewing thread.



**BOWSPRIT HORSE NETTING
SIMPLIFIED FOR MODEL**

NETTING THREAD IS CLOVE-HITCHED TO HORSES AND SPREADERS. MESH IS FORMED BY WEAVING THREAD OVER AND UNDER; TOUCH ALL HITCHES AND CROSSINGS WITH GLUE.

Rigging the yards.—The footropes should be rigged first, followed by the stirrups and Flemish horses, where applicable. Fig. 37A shows the system of seized eyes and lashings which can be used to effect on your model. In the case of the stirrups, these can be modified, using slightly finer cordage than the footrope stuff, clove-hitching them to the yards and to the footropes; make an additional hitch around the yard, glue, and trim.

The lower-, topsail-, and spritsail yards should next be fitted with their brace pendants, measuring their scope from the plans, seizing them snugly to the yardarms, and gluing (Fig. 37B). This method is also good for the main (spanker) gaff vang pendants (Rigging Item #29) and peak halyard bridles (Item #63). Yard tackle pendants, fitted with double blocks, should be seized to the fore and main lower yardarms, port and starboard; these are shown on the rigging plan, but do not reeve the yard tackle purchases as they will be in the way at this time.

The rigging plan will show a number of blocks strapped to the lower- and topsail yards at their quarters (Mid-points); these may be tied in place using knot-work shown in Fig. 37C. This method is in fact useful for tying blocks to a variety of points: to stays, crosstrees, shrouds, booms, etc. You will use it often.

Lower yards—slings, trusses, and lifts.—The lower yards are suspended at their mid-points by rope slings (Fig. 38) and held to the masts by trusses (Fig. 39); Details F and H in the rigging plan offer additional views of this gear; the scope of the slings should be scaled from the model's rigging profile. The bridle should be seized together and seated around the masthead and the yard sling fitted around the yard before lashing both members together with the lanyard.

FIG. 37.

RIGGING OF YARDS

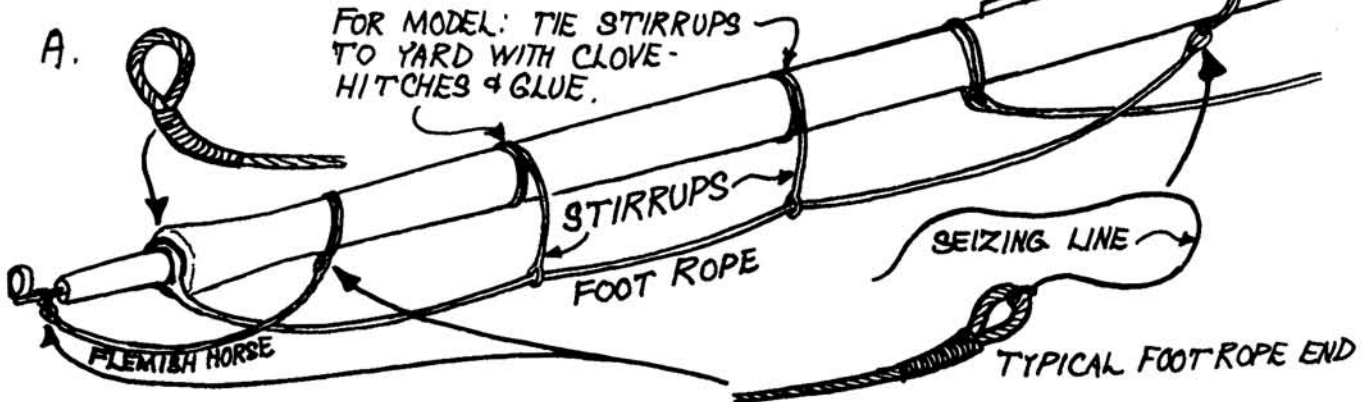

BRACE PENDANT
BRACES OF ROYALS, LIFTS,
& LIFT PENDANTS ARE
SIMILAR.

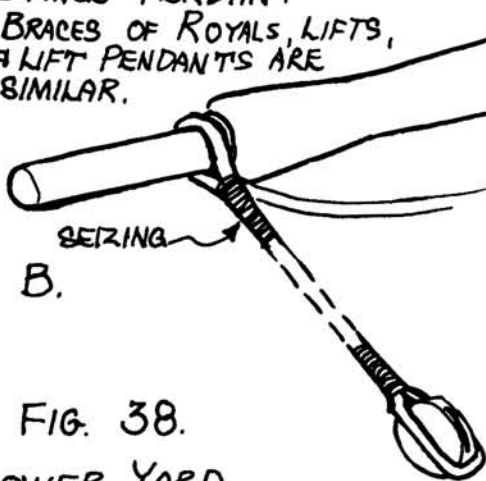

C. STRAPPING BLOCKS
TO YARDS

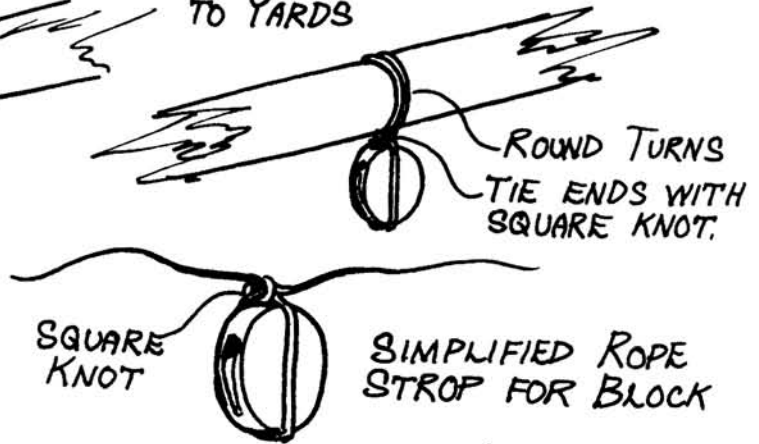

FIG. 38.

LOWER YARD
SLINGS

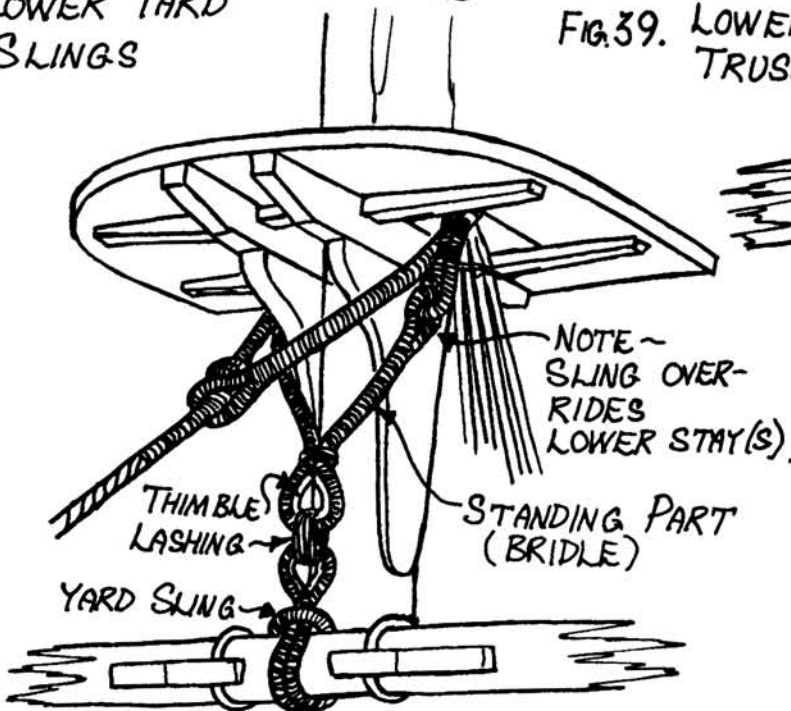
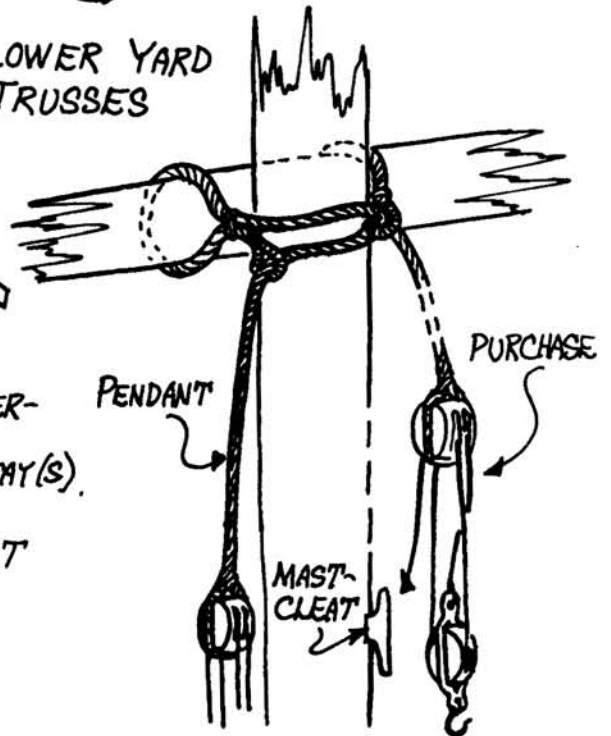
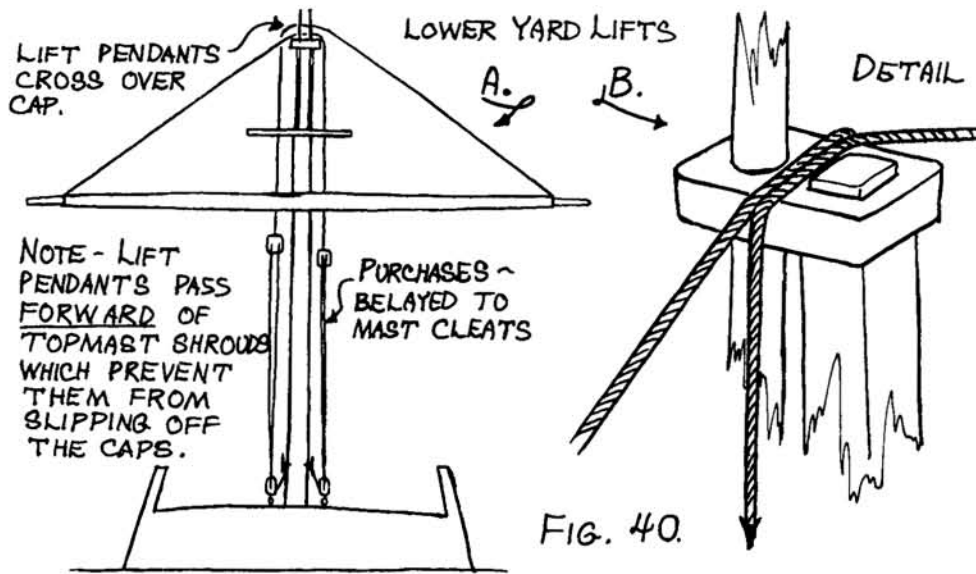

FIG. 39. LOWER YARD
TRUSSES



The lower yard trusses are shown in Fig. 39 and Detail H. The pendants should be made up individually, minus the purchase blocks, fitted to the yards, and "married", reeving the pendants through the eyes of the opposite parts. The upper purchase blocks can now be seized in (The pendants should end about 3" above the deck.); wire-strapped single-becket blocks should be hooked to the deck and the purchases rove and belayed.

The lower yard lifts are shown in Fig. 40; the pendants are seized to the yard arms in the same manner as other pendants. After crossing over the lower mast caps, they are led to purchases below; the upper purchase blocks should be midway between deck and cap when the yard is squared. Purchases similar to the truss purchases are rove off and belayed; in so doing, be sure the yard is trimmed level and not "cockbilled", or tilted.



Topsail yards—halyards, parrels, and lifts.—Before sending these yards aloft, seize the lifts to the yard arms in the same way as the brace pendants. You may also wish to make up the topsail halyard tyes, runners, and tackles and reeve them off before seizing the tyes to the yards. Follow the leads shown in the rigging plan, noting slinging methods (Detail L), and the pendants and lower blocks of the halyard tackles (Detail P.). The standing ends of the topsail yard runners are hooked to eyebolts in the aft ends of the port channels, similar to the halyard tackle pendants. When the topsail yards are slung, the halyards should be trimmed so the yards hang about 1/4" above the lower mast caps.

FORE AND MAIN TOPSAIL YARD PARRELS

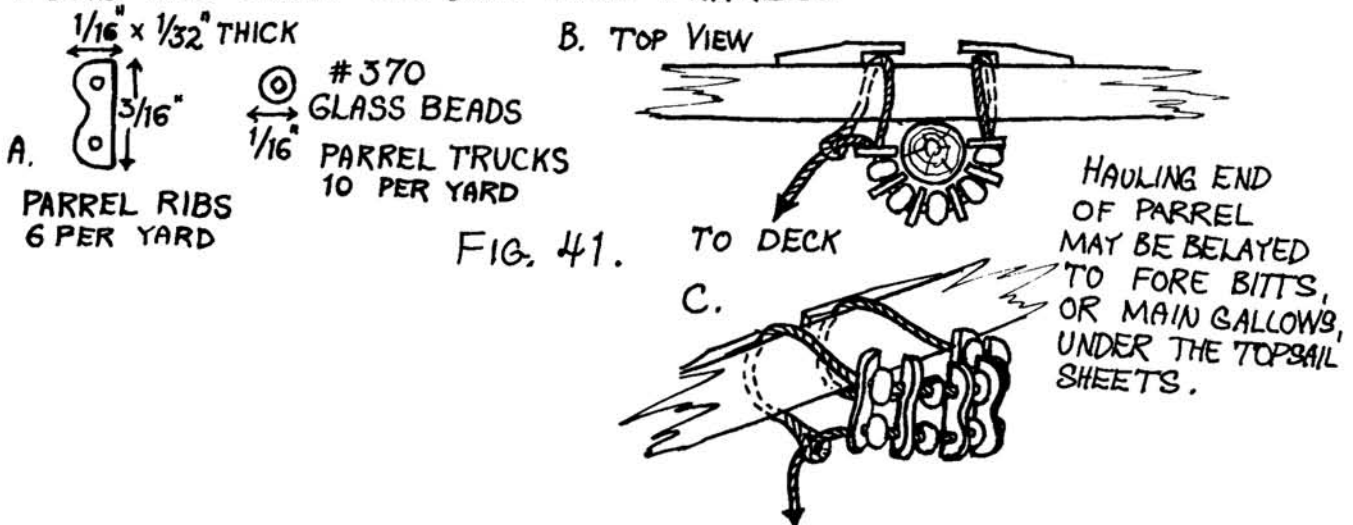

The topsail yard parrels should be made up as shown in Fig. 41. The actual numbers of ribs and trucks needed will vary with the delicacy of the finished parts; if you find it difficult to make the ribs as thin and small as specified, use fewer of them or simply omit the glass beads. Although this detail is very interesting, do not allow it to look heavy or out of proportion with the rest of the topsail yard fittings. When the parrels have been assembled (Part of this job may have to be done with the yards rigged aloft.), the hauling ends should be led below, hauled taut, and belayed. This tension will cause the yards to “cockbill”, but this will be corrected when the lifts are rigged.

The topsail yard lifts are standing lifts—their ends are fixed with no hauling parts. Having fitted them to the yard arms, it is only necessary to seize the upper ends to the topmast shrouds. This seizing is shown in Fig. 33, but the thimble arrangement in the shrouds can be eliminated for simplicity’s sake; put a seizing around the first shroud pair, just below the point where the lift is to be secured. Be sure that the topsail yards hang level and parallel to the lower yards when you have finished adjusting the lift seizings.

Topgallant yards—halyards, parrels, and lifts.—The topgallant halyards consist of tyes and purchases, the lower purchase blocks being hooked to eyebolts on the tops (over the port trestletrees), the hauling ends of the purchases going to the port pin rails. The parrels are simple (Detail R), but also quite small, so you may wish to simplify them further with some hitches and round turns of your own devising. The yard lifts are rigged in the same way as the topsail yard lifts (Fig. 33); however, these too can be modified when seized into the shrouds.

Spritsail yard—parrels and lifts.—The spritsail yard parrels (Detail K) are like the topgallant yard parrels, but larger and more conspicuous; in this case, they should be made as shown, and as neatly as you can. The lifts are running-, or topping-, lifts, being rove through blocks at the bowsprit cap and belayed to the bow pinrail. Again, care should be taken to “square” the yard properly.

Main (spanker) boom—lifts and sheet.—The topping lifts are paired; seized to the boom end, they are rove through single blocks at the main lower mast head, thence to the lift tackles (Rigging item #52) which are set up inboard. The spanker sheet is rigged as shown in the rigging plan and belayed to its traveler block. While this last item calls for a tiny wood cleat fixed to the side of the block, it may be better simply to hitch the sheet to the block at its under side. Coil the end of the main sheet carefully and lay it on the quarter deck.

Main (spanker) gaff—halyards and vang.—The paired vang pendants should be made up, fitted with blocks, and seized to the peak of the gaff. The peak halyard bridles should next be seized in place, and to each other, checking their leads and lengths (not too short!) against the rigging plan. The peak and throat halyards are basically alike, each consisting of a runner which passes through a single block at the masthead and is either hooked to an eye in the gaff jaws or seized to the peak bridle. The whip end of the runner is seized to a single-becket block and the halyard whip is rove off between the runner block and a double block on deck, then belayed. The proportions of the runners and whips are very important; the runner blocks should not fetch up on the masthead blocks when the gaff is lowered, nor should the whips be so short in scope that they cannot raise and peak the gaff properly.

Decide now whether you want the gaff raised, as shown in the rigging plan or lowered, as shown in the model photos in this booklet. If raised, you can then rig the vangs so they will keep the gaff from swinging about aimlessly. A flag halyard can also be rigged from the peak, but you might wish to consider the period, war conditions, and therefore the flag which may be set on your model.

Before rigging the braces. . . Finish off the stay- and yard tackles, hook their ends in place, and belay the hauling ends. If you plan to rig staysail halyards, downhauls, or sheets, this is a suitable time to do so; if other embellishments like tacks, clewlines, reef tackles, and sheets are of interest, study their leads in Steel and Lever and rig them accordingly. Rig all flag halyards and make them fast to shrouds or the flagstaff. Rig the fore tack boomkin guys (Rigging Item #8); bend the anchor hawsers and secure the anchors. In short, get all odd rigging items rigged and made fast.

Braces.—These are the last items of rigging for your model and they make a pleasant, impressive finale! Begin with the topgallant braces, seize them to the yardarms, reeve them off, and belay them, making sure the yards are braced squarely. View the model from directly overhead to be sure of this. The topsail braces are next; follow the rigging- and belaying plans for the correct leads and note especially the leads of the fore topsail braces, which go to lead blocks on the main stay.

The spritsail yard braces are led to the fore top before going to their belaying points at the bulwarks; this yard can be tricky to brace square, so view it from all angles before making fast. The fore lower braces lead to the main top and to deck; the main braces lead to the fore shrouds below the futtock staves before descending to the pin rails. Where these braces cross, be careful not to let them foul each other, an easy thing to do if you’re impatient.

Finishing touches.—If you have left the gun barrels off the carriages, as advised earlier, glue them down at this time. If your model has any shiny spots on the hull or rigging due to handling or excessive amounts of glue, these can be eliminated by giving the model an overhaul spraying with a clear flat (or semi-flat) lacquer such as Krylon “matte finish”. Warning! Test the lacquer spray on a piece of wood painted with your model’s brand of colors to test for compatibility; if the spray causes the paint to wrinkle or crack, don’t use it on your model!

Your model is now ready for transfer to its finished exhibition baseboard. Handle carefully! If pride of workmanship justifies, consider a brass name plate to mount on the board; consult the Model Shipways catalog for details.

This project completed, it is hoped that you have enjoyed building your model of FAIR AMERICAN, and that you have found this project an interesting and informative one. You may enjoy further reading and first-hand study of contemporary material, in which case we suggest that you consult the book lists and lists of museums and galleries in the back of this booklet.

BIBLIOGRAPHY

Historical and Technical Sources

★ Means in Print 1988

1. Chapelle, Howard I., *The History of the American Sailing Navy*, W. W. Norton, 1949. Bonanza reprint. The standard reference on the development of American sailing warship design from the colonial period onward. *Fair American* is not discussed, but there is much useful background information on the Continental Navy and the problems of procuring suitable designs.
2. Chapelle, *The History of American Sailing Ships*, W. W. Norton, 1935. Bonanza reprint. An earlier work of a more general nature which includes interesting discussions of colonial designs and vessels of the Revolution.
3. Chapelle, *The Search for Speed under Sail*, W. W. Norton, 1967. A penetrating analysis of American attempts to design fast sailing vessels from the colonial period to the mid-19th century. Many of the 18th century designs are quite startling and their comparison with *Fair American* is very interesting.
4. Goldenberg, Joseph A., *Shipbuilding in Colonial America*, The Mariners Museum, 1976. A geographical and statistical survey of shipbuilding in the colonies, including warships built for the Admiralty. If nothing else, this book should bury for all time the old myth that colonial shipwrights were a bunch of ignorant farmers.
5. Hutchinson, William, *A Treatise on Naval Architecture*, U.S. Naval Institute, 1969. Reprint of the 1794 edition. The “naval architecture” is cursory and of less interest than the practical discussions of seamanship, navigation, medicine, and warship drill. Provides some wonderful insights to life at sea in an 18th century man-of-war. ★
6. Lever, Darcy, *The Young Sea Officer’s Sheet Anchor*, Sweetman, 1955. Reprint of the 1819 edition. Probably the best-illustrated guide to practical seamanship of its period, this is an extremely helpful aid to visualizing the complexities of the hemp-rigged warship of the early 19th century. Coming almost 40 years after *Fair American*’s time, there are bound to be improvements in rigging techniques and fittings which do not apply to vessels of the 18th century. Beware of jackstays, iron rigging hardware, and some fore-and-aft rigging and check the older sources in Steel if you feel unsure. ★
7. Smith, Philip C.F. (Editor), *The Journals of Ashley Bowen* (1728-1813) of Marblehead, Peabody Museum of Salem, 1973. Ashley Bowen was a Marblehead rigger who kept meticulous journals chronicling the maritime activities

around the Salem-Marblehead area. He liked to dabble in watercolors, filling many pages with fascinating renderings of vessels of all sorts, including a number of brigs scarcely distinguishable from *Fair American*. A superb first-hand account of early Continental Navy activities. ★

8. Steel, David, *Elements of Mastmaking, Sailmaking, and Rigging*, Sweetman, 1960. Reprint from the 1794 edition. Herein lie all the rules, definitions, and tables that can be applied to ships of *Fair American*’s time. The rigging details are mostly in tabular form with few illustrations. If some rigging leads seem cloudy, check with Lever’s *Sheet Anchor* for illustrations of comparable gear. ★
9. U.S. Naval Academy, *Henry Huddleston Rogers Collection of Ship Models*, Naval Institute Press, 1954. Revised edition, 1971. A catalog describing all items in the famous Rogers Collection now at the U.S. Naval Academy. The model of *Fair American*, Number 60, is described on pages 82 and 83. ★

Modeling Techniques

10. Ansted, A. A. *Dictionary of Sea Terms*, Brown, Son, Ferguson, 1967. A very fine collection of general definitions. Compact, well-illustrated. ★
11. Ashley, Clifford W., *The Ashley Book of Knots*, Doubleday & Co., 1944. This great compendium on knots and ropework contains detailed descriptions of nearly all applications of this art to the rigging of ships, much of it pertinent to ship-model rigging as well. An essential bench-side reference for all serious ship model riggers.
12. Campbell, George F., *The Neophyte Shipmodeller’s Jackstay*, Model Shipways, 1962. Describes modelwork of a general nature, drawing examples from many types of sailing ships from different periods. Contains many good hints on crafting techniques with a lot of details pertinent to *Fair American*. ★
13. Craine, J. H., *Ship Modeling Hints & Tips*, Arco, 1973. A collection of articles dealing with the more mysterious and meddlesome modelling techniques. If things like making anchors, gratings, flags, etc. bother you, this book can be very useful.
14. Davis, Charles, G., *How to Make Ship Block Models*, Sweetman, 1970. Useful collection of simplified techniques for making and detailing block-hull models. Includes useful rigging tables. ★

BIBLIOGRAPHY—Continued

15. Davis, *The Ship Model Builder's Assistant*, Sweetman, 1960. Has many useful articles on modelmaking techniques; unfortunately, some of the text dealing with historical aspects of vessels and their construction is inaccurate. Anachronisms abound. Beware! ★
16. Grimwood, Victor R., *American Ship Models*, W. W. Norton, 1942. Bonanza reprint. Contains an interesting collection of American types for modelling subjects; much useful information on modelmaking techniques and a very good chapter on tools and materials.
17. Petrejus, S. W., *Modelling the Brig-of-War IRENE*, "De Esch", Hengelo-Holland, 1970. A beautifully-illustrated volume on building a model of an early 19th century brig-of-war. Some details are too late of period, but descriptions of tools and techniques will be useful to advanced modelmakers. ★
18. Pratt, Winthrop, *A Notebook for Ship Model Builders*, Model Shipways, 1950. A good little beginner's guide to selection of tools and materials. Good articles on sparmaking, rigging, anchors, and masthead construction.
19. Wingrove, Gerald A., *The Techniques of Ship Modelling*, M.A.P., 1974. A detailed, highly informative guide to more specialized ship modelling techniques for vessels of many periods. Strong emphasis on metalworking and use of small precision machinery. For advanced modelmakers.

KEY TO RIGGING PLAN, Sheet 3

Note: standing rigging has been printed in black on the plans: running rigging in red. "P & S" denotes "port and starboard".

1. Fore topgallant stay
2. Jib stay
3. Fore topmast stays
4. Jib stay inhaul
5. Bowsprit horses
6. Bobstay
7. Bowsprit shrouds, P & S
8. Fore track Boomkin guy, P & S
9. Fore stay
10. Sprintsail brace pendants, P & S
11. Main stay
12. Fore lower shrouds, P & S
13. Ratlines, P & S
14. Sheer poles, P & S
15. Main shrouds, P & S
16. Main preventer stay
17. Main topmast stay tackle
18. Fore topmast backstay, P & S
19. Fore topgallant backstay, P & S
20. Main topmast backstay, P & S
21. Main topgallant backstay, P & S
22. Main stay tackle pendant
23. Yard tackle pendants, P & S
24. Mast tackle pendants, P & S
25. Stirrups, P & S
26. Footropes, P & S
27. Fore brace pendants, P & S
28. Main brace pendants, P & S
29. Vang pendants, P & S
30. Flemish horses, P & S
31. Fore topsail brace pendants, P & S
32. Main topsail brace pendants, P & S
33. Fore topmast shrouds, P & S
34. Main topmast shrouds, P & S
35. Topsail yard lifts, P & S
36. Main topmast stay
37. Topgallant yard lifts, P & S
38. Main topgallant stay
39. Jibstay outhaul tackle

40. Sprintsail yard lifts, P & S
41. Sprintsail yard braces, P & S
42. Fore runner tackle, P & S
43. Fore tackle runner, P & S
44. Main tackle runner, P & S
45. Main runner tackle, P & S
46. Fore topgallant backstay runner, P & S
47. Main topgallant backstay runner, P & S
48. Throat halyard tackle
49. Yard tackles, P & S
50. Fore stay tackle
51. Main stay tackle
52. Main boom topping lift tackle, P & S
53. Main boom topping lift runner, P & S
54. Vangs, P & S
55. Spanker (main boom) sheet
56. Fore topsail halyard tackle
57. Main topsail halyard tackle
58. Throat halyard
59. Main brace, P & S
60. Fore topsail brace, P & S
61. Fore brace, P & S
62. Peak halyard
63. Peak halyard bridles
64. Lower yard topping lifts, P & S
65. Main topsail brace, P & S
66. Burton tackles, P & S
67. Burton tackle pendants, P & S
68. Fore topsail halyard tye
69. Fore topsail halyard runner
70. Fore topgallant halyard tackle
71. Main topsail halyard tye
72. Main topsail halyard runner
73. Main topgallant halyard tackle
74. Main topgallant brace, P & S
75. Fore topgallant brace, P & S
76. Fore topgallant halyard tye
77. Main topgallant halyard tye
78. Flat halyards, P & S
79. Ensign halyard

Note: Rigging details, keyed in letters, are described on the rigging plan.

RIGGING TABLES FOR *FAIR AMERICAN*

Note: Cordage diameters given below are based on rigging tables in Steele (1794) for a naval brig of 160 tons. Since *Fair American's* tonnage was considerably less, the diameters in Steel's tables have been reduced approximately by 25%. This reduction varies somewhat, depending on the purpose of each element of the rigging. For instance, horses (footropes) were not reduced as their diameters reflect the weight of the men on them, rather than stress under sail; also, parrels and other cordage subject to chafing have been reduced by only 10–15% rather than a proportionate reduction on rigging tension. These reduced diameters are probably the smallest dimensions deemed practical for a brig of this period and the larger elements of rigging (shrouds, stays, etc.) correspond well to schooners of *Fair American's* period and tonnage as recorded in the Ashley Bowen papers (See bibliography).

Item (and rigging key number)	Cordage diameter	Notes
Gammoning	1"	Tarred
Bob stay (6)	1 ³ / ₈ "	Tarred and served; 2" lanyards
Bowsprit shrouds (7)	1 ³ / ₈ "	Tarred and served; 2" lanyards
Bowsprit horses (5)	1 ³ / ₈ "	Tarred; ends served; ¼" netting
Fore tack Boomkin guys (8)	1"	Tarred; ends served
Mast tackle pendants (24)	1½"	Tarred and served
Fore and main tackle runners (43, 44)	1"	Cargo hooks
Fore and main tackle runners (42, 45)	5⁄8"	Hook standing parts to channels
Fore main shrouds (12, 15)	1½"	Tarred: served at mastheads; lanyards ¾"
All ratlines, fore and main (13)	¾"	Tarred
Fore stay (9)	2"	Tarred; served at masthead; lanyards ¾"
Main preventer stay (16)	1½"	Tarred: served at masthead
Main stay (11)	2¼"	Tarred: served at masthead
Main stay tackle pendant (22)	1"	Tarred; served at ends
Fore and main stay tackles (50, 51)	5⁄8"	Cargo hooks
Burton tackle pendants (67)	¾"	Tarred and served
Burton tackles (66)	½"	Cargo hooks
Fore and main futtock shrouds	7⁄8"	Tarred
Fore and main topmast shrouds (33, 34)	7⁄8"	Tarred: served at mastheads; lanyards ½"
Fore and main topmast backstays (18, 20)	7⁄8"	Tarred: served at mastheads; lanyards ½"
Fore topmast stay (3)	1"	Tarred; served at masthead and bees
Fore topmast stay tackles	5⁄8"	Fiddle blocks
Jib stay (2)	7⁄8"	Tarred; served at masthead and outhaul ring
Jib stay outhaul tackle (39)	½"	Fiddle block
Jib stay inhaul (4)	¾"	Seized to outhaul ring
Main topmast stay (36)	1"	Tarred; served at masthead
Main topmast stay tackle (17)	5⁄8"	Fiddle block
Fore and main tgl't. shrouds	½"	Tarred; served at mastheads
Fore and main tgl't., backstays (19,21)	½"	Tarred; served at mastheads
Fore and main tgl't., runners (46, 47)	¾"	
Fore and main topgallant stays (1, 38)	5⁄8"	Tarred; served at mastheads
Fore and main lower yard slings	1¼"	Tarred and served
Fore and main lower yard trusses	1"	Pendants tarred; tackles ¾"
Fore and main yard tackle pendants (23)	1"	Tarred and served
Fore and main yard tackles (49)	5⁄8"	Cargo hooks
Fore and main lower yard horses (26)	1"	Tarred and served; stirrups 5⁄8"
Fore and main lower brace pendants (27, 28)	7⁄8"	Tarred and served
Fore and main lower braces (59, 61)	¾"	
Fore and main lower lifts (64)	¾"	Tarred; tackles ½"
Fore and main topsail yard parrels	5⁄8"	Tarred
Fore and main topsail yard tyes (68, 71)	7⁄8"	Tarred
Fore and main topsail halyard runners (69, 72)	5⁄8"	Lightly tarred
Fore and main topsail halyard tackles (56, 57)	¾"	
Fore and main topsail yard horses (26)	7⁄8"	Tarred and served; ½"
Fore and main topsail lifts (35)	½"	Tarred; served at yardarms
Fore and main topsail brace pendants	¾"	Tarred and served
Fore and main topsail braces (60, 65)	½"	
Fore and main tgl't. yard tyes (76, 77)	½"	Tarred
Fore and main tgl't. halyards (70, 73)	¾"	
Fore and main tgl't. horses (26)	½"	Tarred and served; stirrups ¾"
Fore and main tgl't. parrels	¾"	Tarred
Fore and main tgl't. lifts (37)	¾"	Tarred; served at yardarms

RIGGING TABLES FOR *FAIR AMERICAN*—Continued

Item (and rigging key number)	Cordage diameter	Notes
Fore and main tgl't. braces (74, 75)	$\frac{3}{8}$ "	
Spritsail yard sling	$\frac{7}{8}$ "	Tarred
Spritsail yard lifts (40)	$\frac{1}{2}$ "	
Spritsail yard horses (26)	$\frac{5}{8}$ "	Tarred and served; stirrups $\frac{1}{2}$ "
Spritsail brace pendants (10)	$\frac{3}{4}$ "	Tarred and served
Spritsail braces (41)	$\frac{1}{2}$ "	
Main boom topping lift runners (53)	1"	Lightly tarred
Main boom topping lift tackles (52)	$\frac{5}{8}$ "	
Spanker sheet (55)	$\frac{7}{8}$ "	
Peak halyard bridles (63)	$\frac{3}{4}$ "	Tarred; served at gaff
Throat and peak halyard runners (58, 62)	$\frac{7}{8}$ "	Lightly tarred; whips $\frac{5}{8}$ "
Vang pendants (29)	$\frac{5}{8}$ "	Tarred; served at peak; vangs $\frac{3}{8}$ "
Cat falls	$\frac{7}{8}$ "	Anchor lashings same diameter
Flag halyards (78)	$\frac{1}{4}$ "	Ensign halyard (79) $\frac{3}{8}$ "

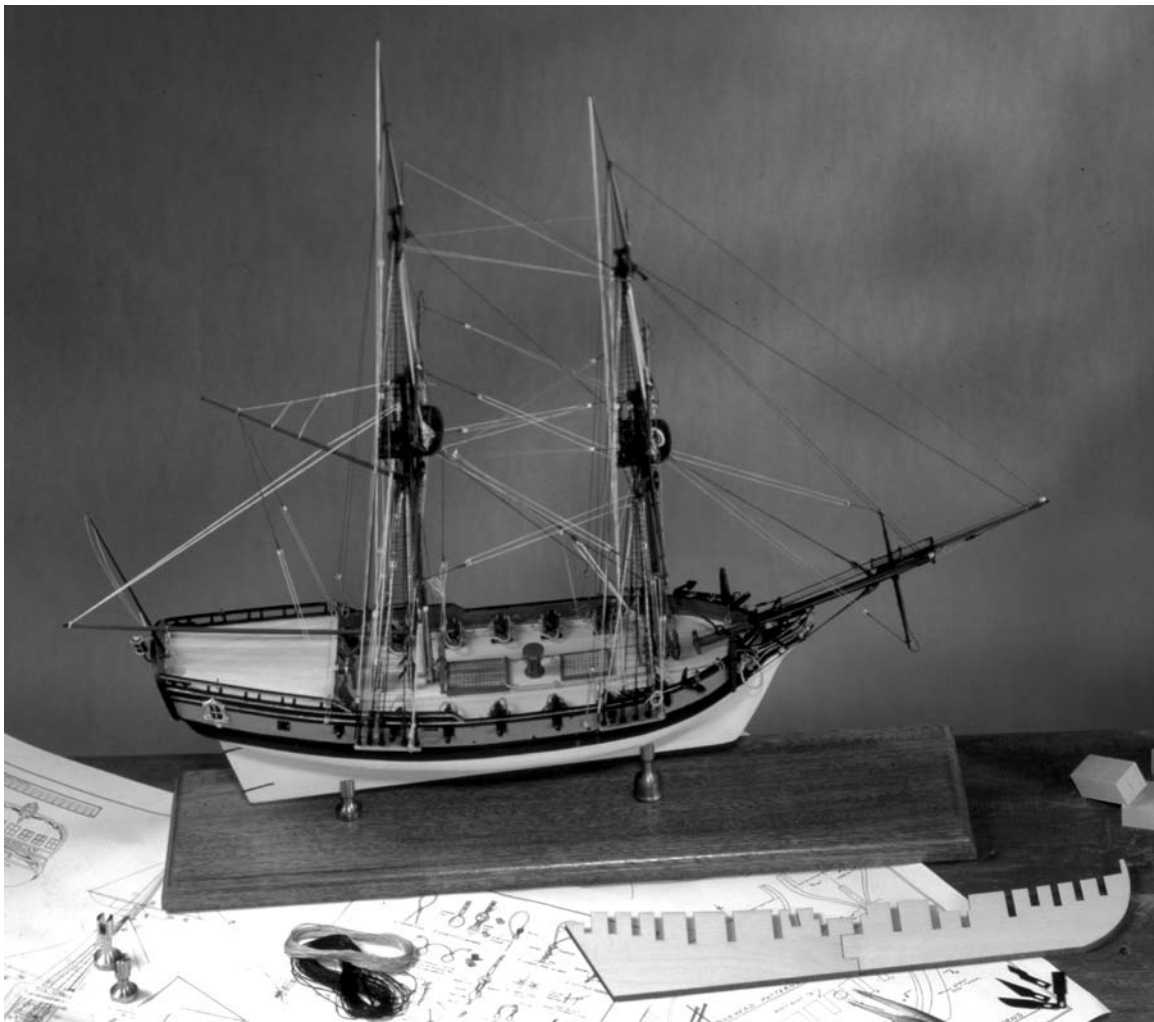

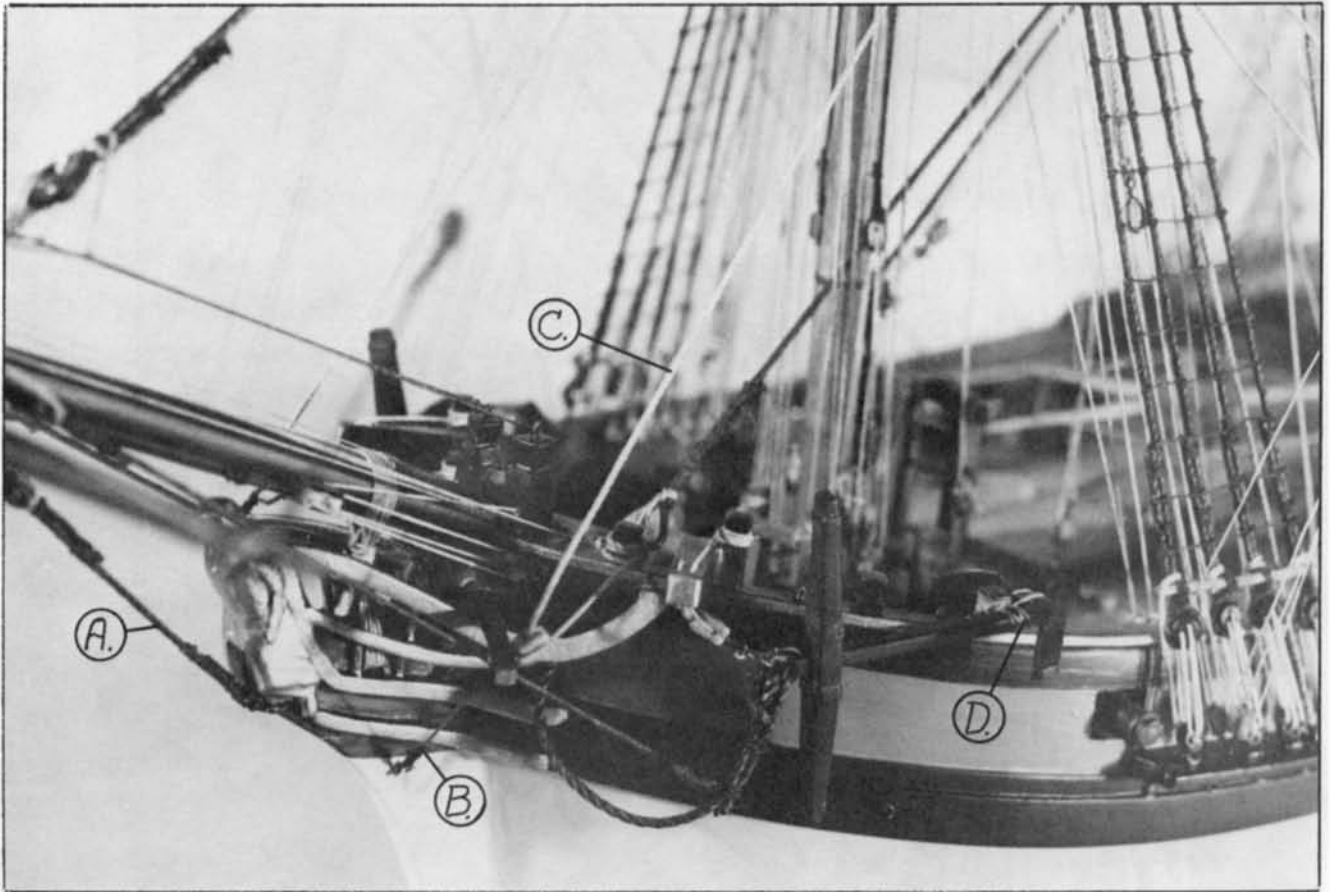

Port Bow. A. Bobstay, B. Fore tack boomkin guy, C. Fore tack, D. Anchor lashings.

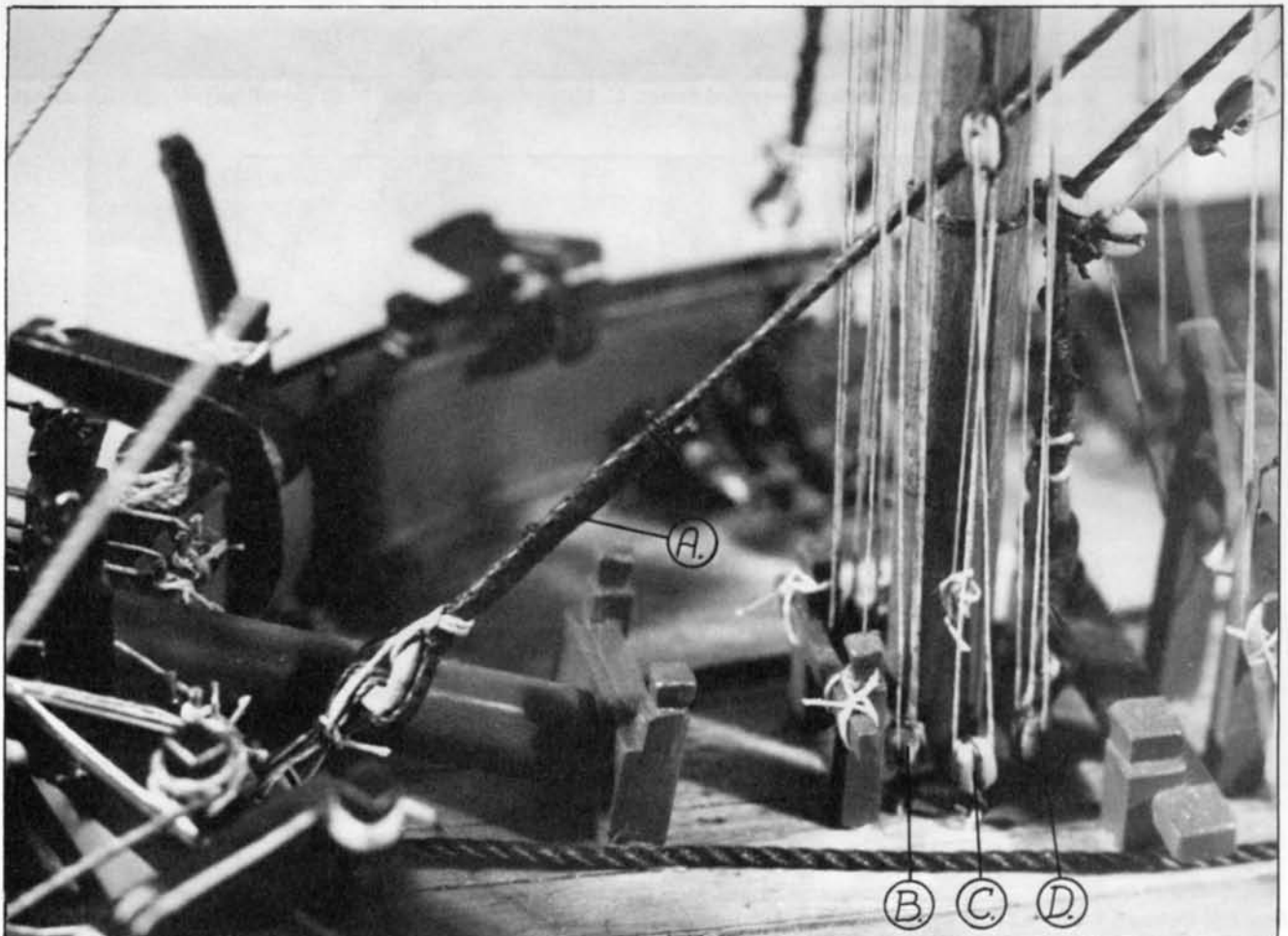

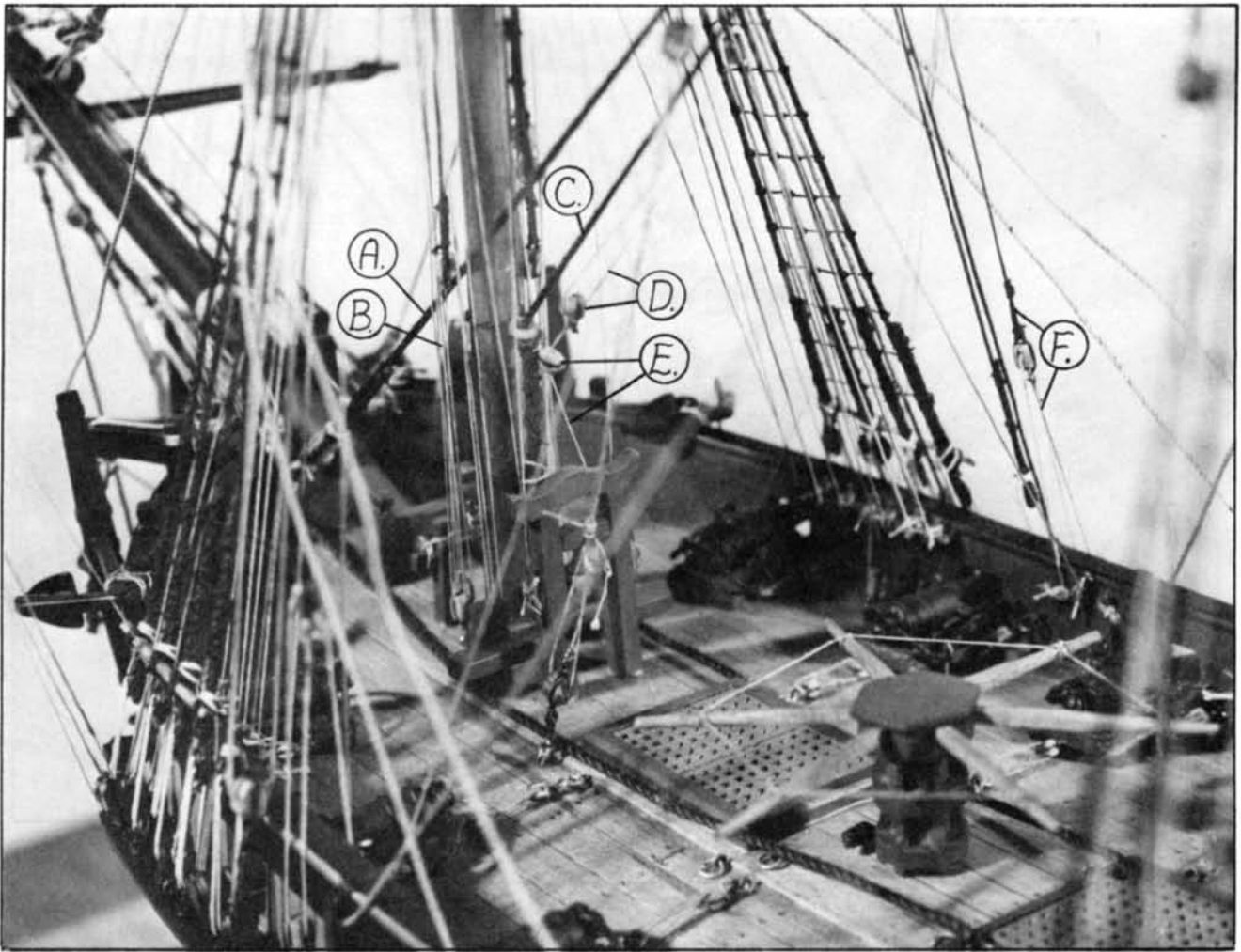

Main deck, looking forward. A. Main stay, B. Fore lower yard trusses. C. Main preventer stay, D. Main staysail halyard, E. Main staysail downhaul. F. Fore topgallant backstay and runner.

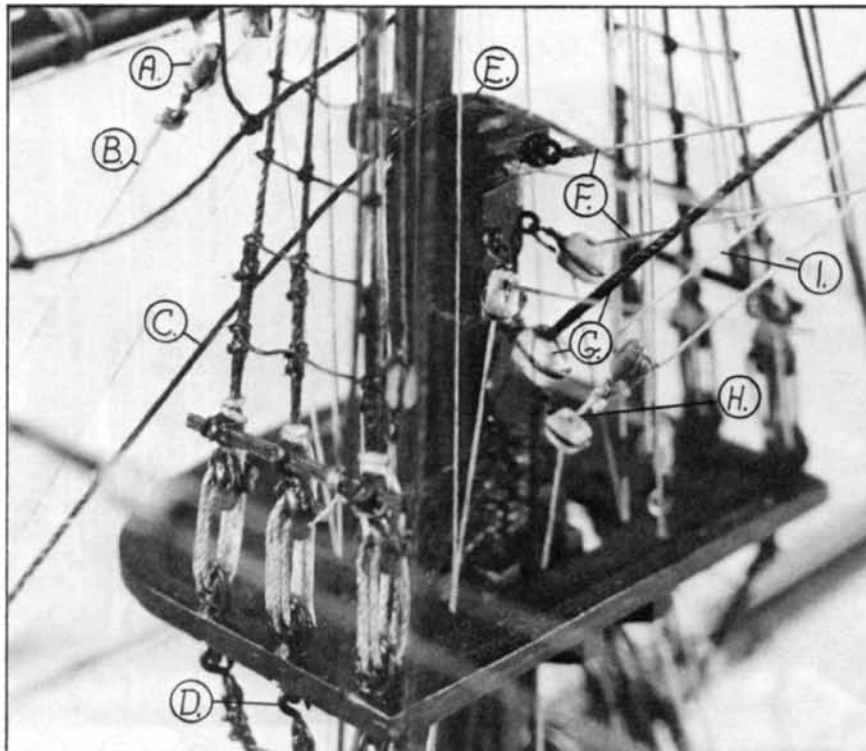

Fore top, looking forward. A. Fore topsail clewline block, B. Fore topsail sheet, C. Fore lower yard lift, D. Futtock hooks, E. Lower yard lifts, crossing over at cap, F. Main topsail braces, standing and running parts, G. Main topmast stay and fairlead block, H. Main topmast staysail downhaul, I. Main topmast staysail halyard.

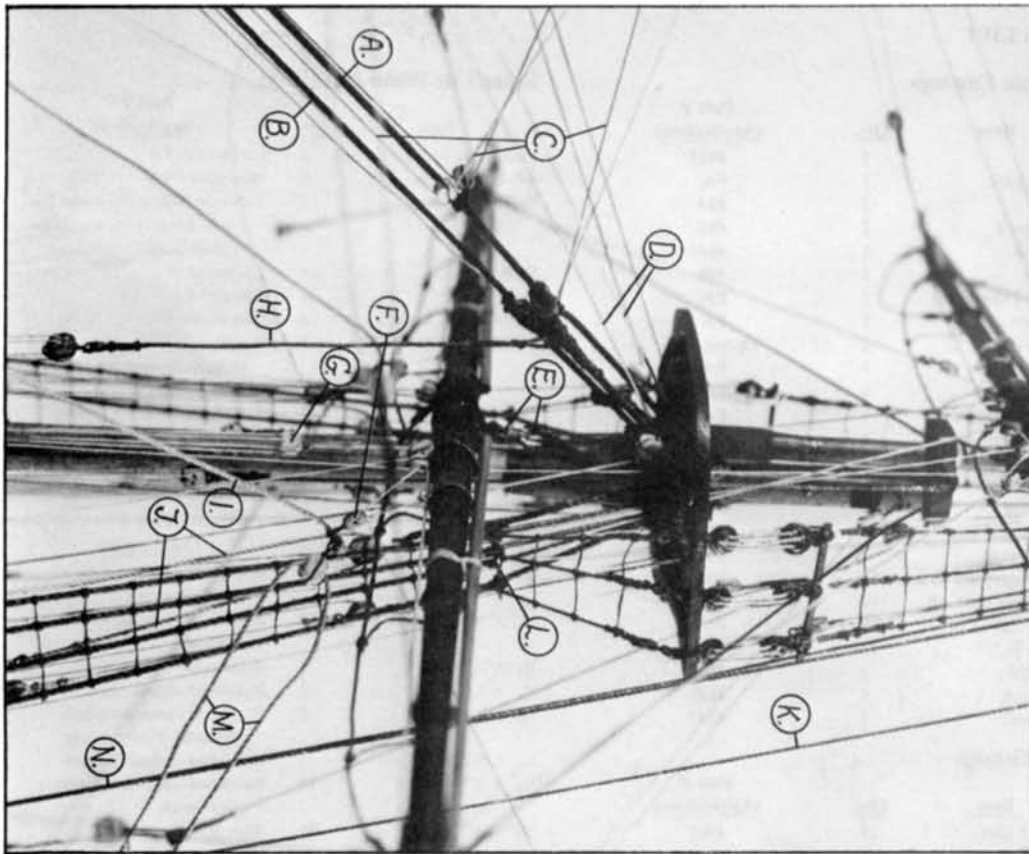

Main top. A. Main stay, B. Main preventer stay, C. Fore topsail braces, standing and running parts, D. Fore braces, standing and running parts, E. Main lower yard sling, F. Main clew garnet block, G. Main topsail sheet, H. Main stay tackle, I. Main tack, J. Main mast tackle runner, K. Main topgallant backstay, L. Futtock stave, M. Main sheet, N. Main topmast backstay.

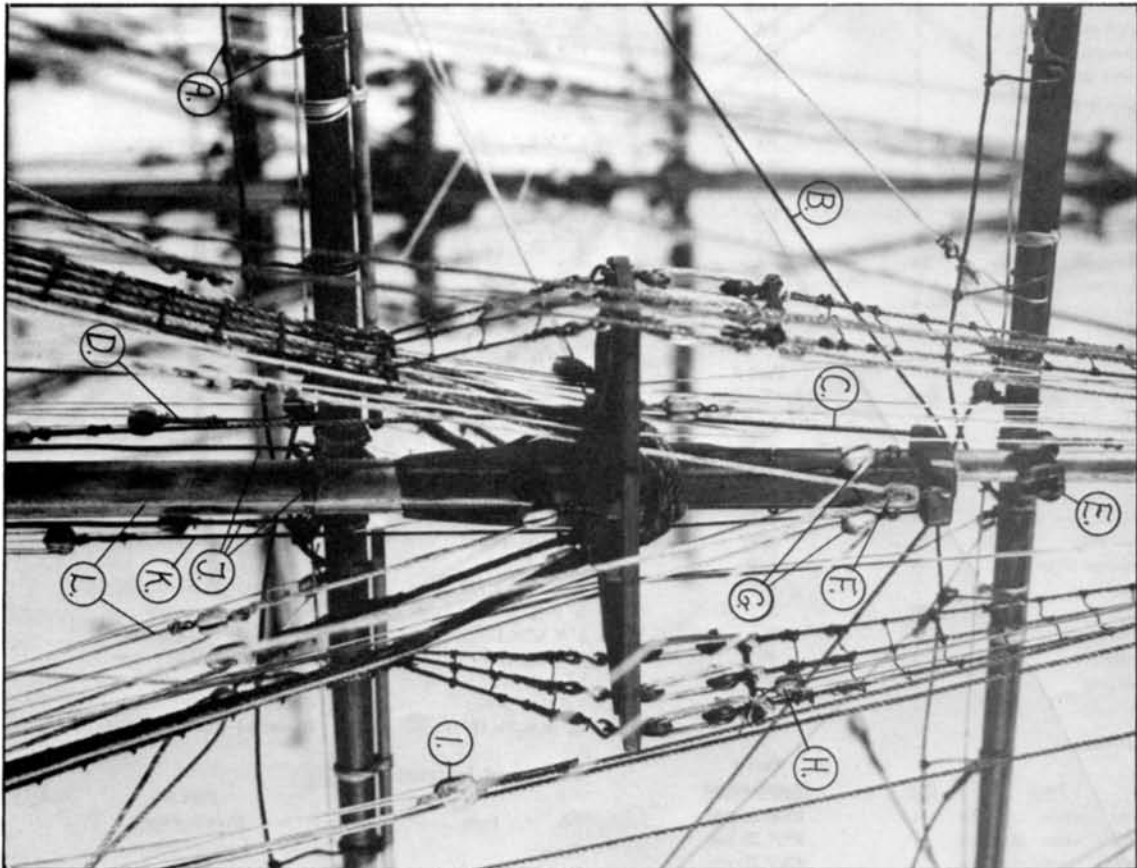

Main top, looking forward. A. Footropes and stirrups, B., C. Main lower yard lifts, D. Main topsail sheet, E. Main topsail yard parrels, F. Peak Halyard, G. Main boom topping lifts, H. Burton tackle, I. Main topsail halyard, J. Main lower yard truss, K. Main lower yard lifts, L. Throat halyard.

Other Fine Kits from Model Shipways



SULTANA
Model Shipways Kit No. MS2016



WILLIE L. BENNETT
Model Shipways Kit No. MS2032



BLUENOSE
Model Shipways Kit No. MS2130



RATTLESNAKE
Model Shipways Kit No. MS2028



CHARLES MORGAN
Model Shipways Kit No. MS2140



BENJAMIN LATHAM
Model Shipways Kit No. MS2109

OUR GUARANTEE

If less than delighted, return your purchase within 30 days in original condition.

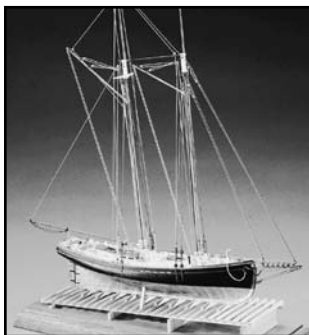

PHANTOM
Model Shipways Kit No. MS2027



EMMA C. BERRY
Model Shipways Kit No. MS2150



BEDFORD WHALEBOAT
Model Shipways Kit No. MS2645



USS CONSTITUTION
Model Shipways Kit No. MS2040



NIAGARA
Model Shipways Kit No. MS2240



FLYING FISH
Model Shipways Kit No. MS2018



PRINCE DE NEUFCHATEL
Model Shipways Kit No. MS2110



PRIDE OF BALTIMORE II
Model Shipways Kit No. MS2120

MODEL SHIPWAYS, INC.

Sold & Distributed by Model Expo, a division of Model Shipways, Inc.
3850 N. 29th Terrace, Hollywood, FL 33020

Toll-Free 800-222-3876 Monday - Friday 9-6 ET • Fax 800-742-7171

SAVE TIME & MONEY... ORDER DIRECTLY FROM OUR WEBSITE!
<http://www.modelexpo-online.com>